



SHENGHAO MACHINE TOOL ACCESSORIES



Cable-chain System
2026.5

>>>

HIGH LEADING DIRECTION

Lead the industry <<<

Company profile |

Cangzhou Shenghao Machine Tool Accessories Co., Ltd. mainly engages in plastic cable drag chains, steel cable drag chains, bellow covers, steel telescopic cover, chip conveyor and other machine tool protection products. Founded in 2007, the company has 150 employees, including 25 technical R&D personnel. It is equipped with advanced mold manufacturing equipment and sheet metal processing equipment.

Adhering to the business philosophy of excellent quality, innovative spirit and customer orientation, the company focuses on customized solutions for machine tool protection and cable protection, and delivers high-quality services to customers from all walks of life.

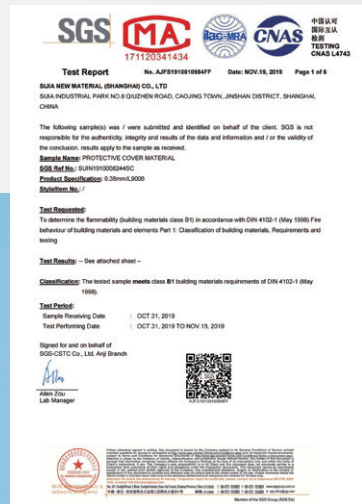
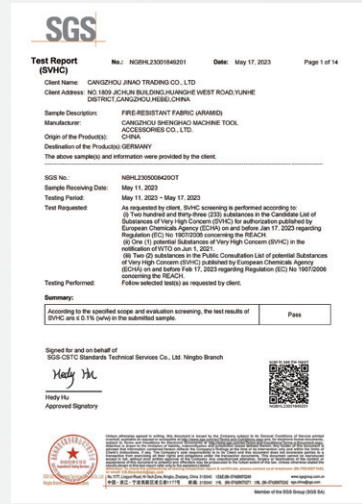
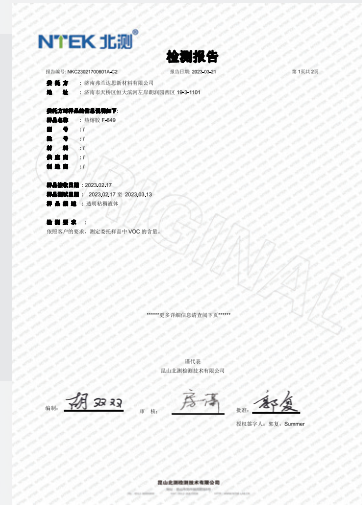

Quick Selection

Legend	Opening principle	Series	Inner height [mm]	Inner width [mm]	Outer height [mm]	Outer width [mm]
Micro series						
Overall						
		W7	7	7	10.2	12.3
		W10	10	10-20	15	17.5-27.5
CompactSize series						
Open along inner bending radius						
		B15	15	15-40	20	25-50
		B18	18	18-50	23.5	28-60
		B25	25	25-100	35	42-117
Open along outer bending radius						
		B15i	15	15-40	20	25-50
		B25i	25	25-100	35	42-117
Light Duty series						
Bridge type Upper & lower cover openable						
		L25Q	25	25-75	40	40-90
		L35Q	35	50-250	55	76-176
Fully enclosed Upper & lower cover openable						
		L25F	25	25-75	40	40-90
		L35F	35	50-150	55	76-176
Full Black series						
Bridge type Upper & lower cover openable						
		H35Q	35	50-250	55	76-276
		H45Q	45	50-250	65	82-282
		H55Q	55	50-250	75	82-282
		H62Q	62	60-300	87	100-340
		H80Q	80	60-300	106	109-349
Fully enclosed Upper & lower cover openable						
		H35F	35	50-150	55	76-176
		H45F	45	60-150	65	82-182
		H55F	55	60-150	75	82-182
		H62F	62	100-200	87	100-240
		H80F	80	150-300	106	109-349



Bending radius R[mm]	Pitch [mm]	Fictitious load [kg/m]	Span length [m]	Glide length [m]	Internal Separation		Page
15-48	16.9	0.33	1.0				15
28	20	0.7	1.5				17
28-48	25	1.2	1.5				19
28-75	30.5	1.5	3.0				21
38-100	44	4.8	3.7		●	●	23
28-48	25	1.2	1.5				
38-100	44	4.8	3.7		●	●	
55-250	47	4.8	3.7	95	●		25
75-300	67	9.5	5.2	120	●	●	29
55-250	47	4.8	3.7	95			25
75-300	67	9.5	5.2	120			29
75-300	67	23	6.5	190	●	●	33
100-350	80	36	7.5	240	●	●	37
125-300	80	58	9.0	335	●	●	41
150-500	90	68	10	350	●	●	45
150-500	110	75	12	350	●	●	49
75-300	67	23	6.5	190			33
100-350	80	36	7.5	240			37
125-300	80	58	9.0	335			41
150-500	90	68	10	350			45
150-500	110	75	12	350			49

Quick Selection

Legend	Opening principle	Series	Inner height [mm]	Inner width [mm]	Outer height [mm]	Outer width [mm]
Yellow Buckle Economy series						
Bridge type Upper & lower cover openable						
		K20Q	20	25-103	35	48-126
		K25Q	25	25-103	40	49-127
		K30Q	30	25-103	45	50-128
		K35Q	35	50-250	55	78-278
		K45Q	45	50-250	65	83-283
		K55Q	55	50-250	74	81-281
Fully enclosed Upper & lower cover openable						
		K20F	20	25-75	35	48-98
		K25F	25	25-75	40	49-99
		K30F	30	25-75	45	50-100
		K35F	35	50-150	55	78-178
		K45F	45	60-150	65	93-183
		K55F	55	60-150	74	91-181
Yellow Buckle Economy series						
Bridge type Upper & lower cover openable						
		Z35Q	35	50-200	58	80-230
		Z45Q	45	50-200	68	80-230
		Z56Q	56	60-300	94	102-342
		Z62Q	62	60-300	100	103-343
		Z80Q	80	60-300	118	106-346
		Fully enclosed Upper & lower cover openable				
		Z35F	35	50-150	58	80-180
		Z45F	45	50-150	68	80-180
		Z56F	56	100-200	94	102-242
		Z62F	62	100-200	100	103-243
		Z80F	80	150-300	118	106-346
		Low Noise series				
Upper & lower cover openable						
		JY25	25	38-100	36	59-121
		JY35	35	50-100	46	74-124

Bending radius R[mm]	Pitch [mm]	Fictitious load [kg/m]	Span length [m]	Glide length [m]	Internal Separation		Page
55-125	47	1.7	3.5	70			53
55-150	47	4.8	3.7	95	●		57
55-150	47	5.3	4.0	100	●		61
75-300	67	58	9.0	335	●	●	65
100-350	80	68	10	350	●	●	69
125-300	80	75	12	350	●	●	73
55-125	47	1.7	3.5	70			53
55-150	47	4.8	3.7	95			57
55-150	47	5.3	4.0	100			61
75-300	67	58	9.0	335			65
100-350	80	68	10	350			69
125-300	80	75	12	350			73
75-300	66	23	6.5	190	●		77
75-300	66	36	7.5	240	●		81
125-300	90	58	9.0	335	●	●	85
150-500	100	68	10	350	●	●	89
150-600	110	75	12	350	●	●	93
75-300	66	23	6.5	190			77
75-300	66	36	7.5	240			81
125-300	90	58	9.0	335			85
150-500	100	68	10	350			89
150-600	110	75	12	350			93
55-100	22	3.5	3.0				97
75-100	25	4.5	3.5				99

Unsupported | Short Travels



Overhead Definition: The upper and lower sections of the drag chain keep non-contact during operation. Overhead application is the most common working condition. The maximum overhead span depends on the drag chain type and internal load.

Drag Chain Length Calculation

For common linear motion, if the fixed end is set at the mid-travel position, the drag chain length $L_k = \text{half travel } S/2 + K$ value. If the fixed end deviates from the midpoint with an offset ΔM , this offset value shall be added additionally.

- Fixed end at mid-travel

$$L_k = S/2 + K$$

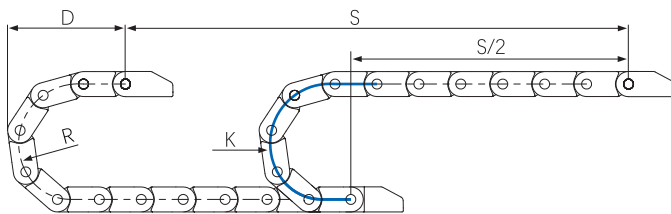

- Fixed end with midpoint offset

$$L_k = S/2 + K + \Delta M$$

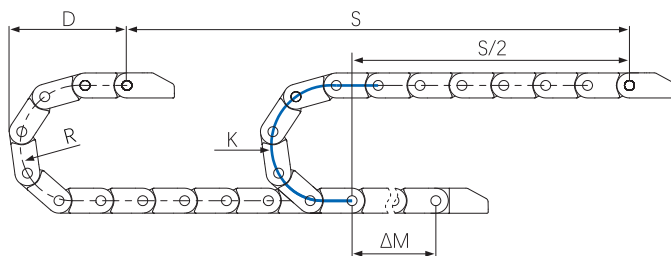

Installing the fixed end at the mid-travel position is the most cost-effective solution!

$$K = \pi \cdot R + 2 \cdot P$$

L_k = Drag Chain Length

S = Travel Distance

R = Drag Chain Bending Radius

P = Chain Pitch

ΔM = Midpoint Offset Distance

K = Overhead Bending Radius Margin

The K value can be found in the technical table of each drag chain series.

Overhead

Overhead Span: The unsupported distance from the moving end to the starting point of the bending arc. It is divided into three types according to the operating state:

1. Straight Overhead (FLG)

The drag chain presents a slight upward camber, straight state, or sagging distance less than 1/2 of the outer height. It is the most recommended mode with stable operation and minimum wear.

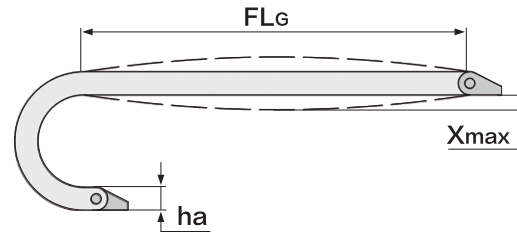

$$FL_G : X_{max} \leq 1/2 \cdot ha$$

The upper section is slightly arched upward, kept straight, or the sagging distance is less than 1/2 of the outer height.

2. Safe Sagging (FLB)

The sagging distance is greater than 1/2 of the outer height and smaller than the minimum bending radius of the series. It is suitable for low-speed and low-acceleration occasions, with increased wear, vibration and noise.

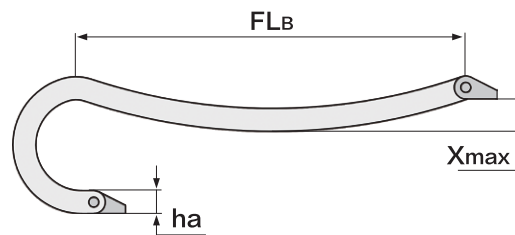

$$FL_B : 1/2 \cdot ha < X_{max} \leq R_{min}$$

The sagging distance of the drag chain is greater than 1/2 of its outer height and smaller than the minimum bending radius of the series.

3. Dangerous Sagging

Dangerous sagging will seriously reduce drag chain service life and threaten equipment safety, which must be avoided in design. Dangerous sagging may occur after long-term operation; please replace the drag chain or optimize the design and contact us for technical support.

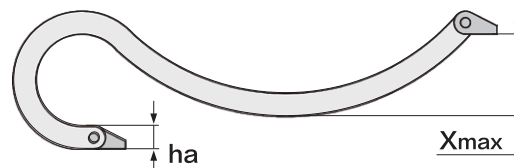

$$\text{Dangerous Sagging: } X_{max} > R_{min}$$

The sagging distance exceeds the minimum bending radius of the drag chain series.



Each series product page is attached with an Overhead-Load Diagram. Select the optimal drag chain and overhead mode according to the actual span and load.

Unsupported | Short Travels

Preload

Preload refers to the upward camber of the upper segment of the drag chain during operation. All our drag chains are designed with preload, which can increase the overhead span and extend service life.

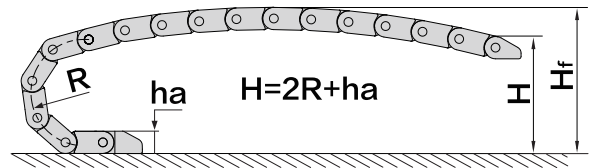

Installation Height

For preloaded drag chains, the actual installation height H_f is greater than the theoretical installation height H . Refer to the installation dimensions on the corresponding product page for the H_f value of each model.

Connector

We recommend movable connectors as the standard configuration for overhead applications. Movable connectors compensate for drag chain preload, reduce the load on the first chain link during operation, and facilitate installation.

Exception: When the acceleration exceeds 20m/s^2 or the actual installation height H_f is limited, locking connectors are recommended. They limit the installation height within the H_f range and effectively prevent drag chain jumping.

Mounting Surface

For overhead operation, lower support for the drag chain is generally required. The support surface can be made of various forms and materials, such as metal, stone, concrete, etc. If lower support is unavailable, it is defined as overhead suspension. The maximum overhead suspension length FL_u depends on the drag chain load, operating conditions and other factors. It is recommended that the maximum suspension length be less than $1/4$ of the straight overhead length.

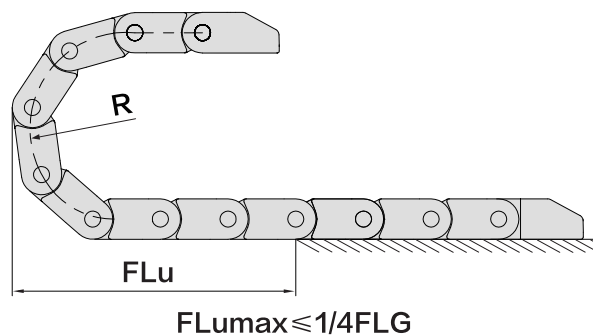

Ratio of Bending Radius to Pitch

The larger the ratio of bending radius to pitch, the closer the curved section of the drag chain is to a circular arc, resulting in smoother operation, lower vibration and less noise.

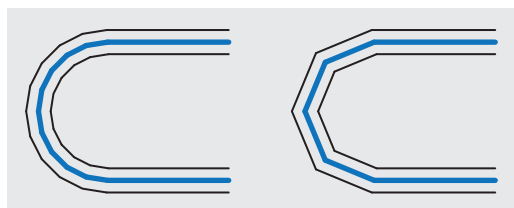

R/P values: larger on the left, smaller on the right

Overhead Support

If the overhead span of the selected drag chain is insufficient, the following solutions are available.

- 1) Select a drag chain with higher load capacity or better overhead performance
- 2) Add supports in the overhead area. Three basic support modes are available with rollers or support trays.

1. Single support

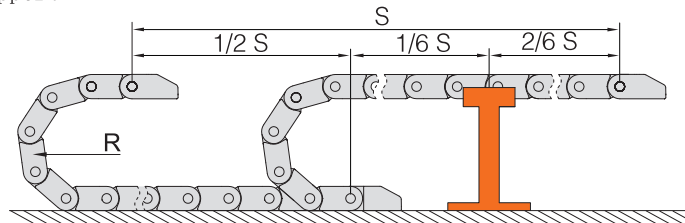

2. Doubles the overhead travel: Max Travel = $4 \cdot F_{LG}$

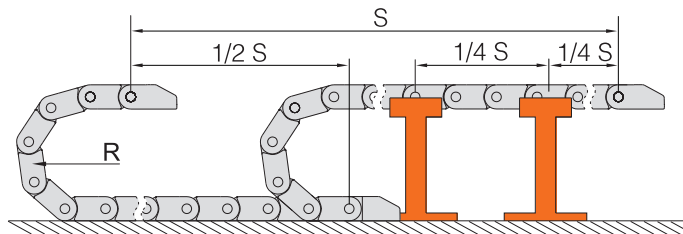

3. Sectional support: Doubles the overhead travel: Max Travel = $4 \cdot F_{LG}$

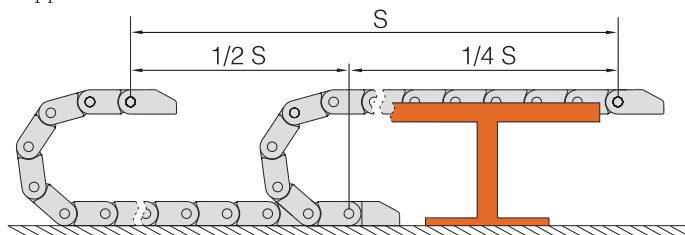

Note: Additional supports will affect the operating speed and acceleration to a certain extent, and may cause extra noise and vibration.

3) Split & Nested Overhead Application

When installation height and width are limited while larger internal filling space is required, split or nested installation of two drag chains is recommended. This method also solves the problem of insufficient overhead span.

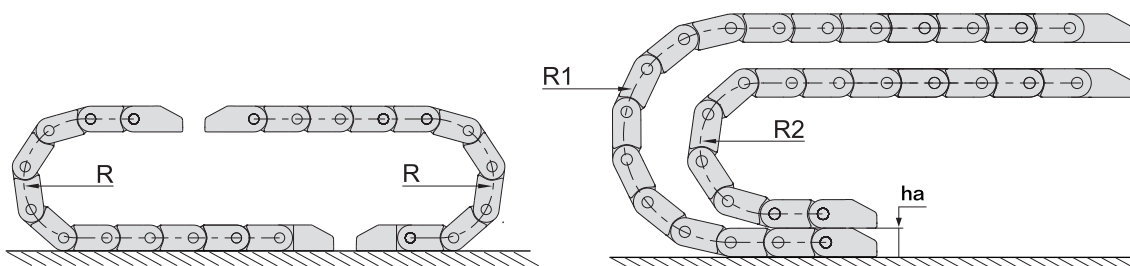

4) Adopt sliding application design

Sliding Application | Long Travels

Sliding Application



When the overhead span is insufficient, the sliding solution is the optimal choice for long-travel applications, with a maximum travel of several hundred meters, widely used in automobile, port and other industries. The upper drag chain is supported by the lower section; part of the upper chain slides on the lower chain, and the rest slides on equal-height wear strips. Guide channels must be used to prevent lateral displacement. It is necessary to reduce the installation height of the moving end and reversely mount the first several chain links.

Calculation of drag chain length for gliding scheme

● Single drag chain sliding:

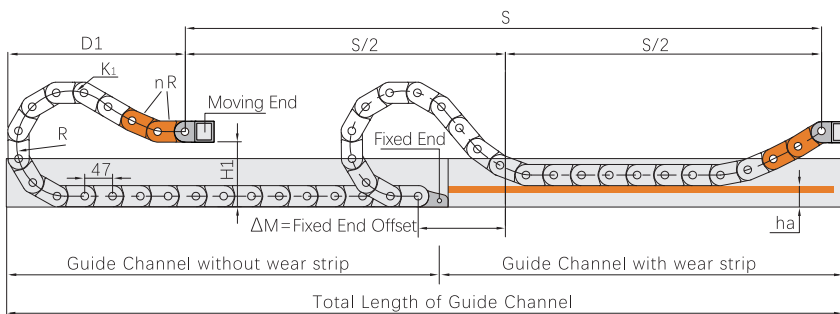

● Two-way open drag chain sliding: used for limited spaces or high loads

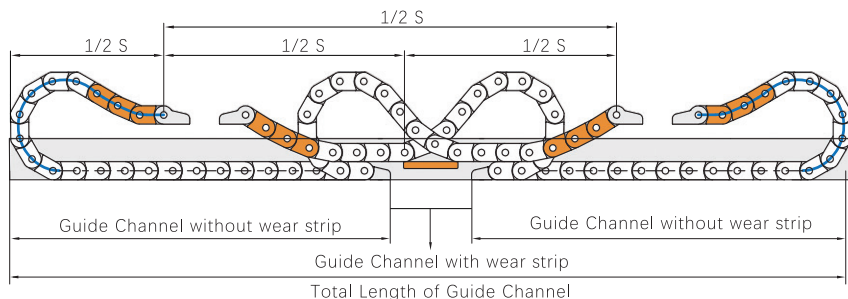

Reducing the installation height on mobile devices and reversing the first few sections of the cable carrier is very important!

$$L_k = \frac{S}{2} + K_1$$

L_k = Drag Chain Length

S = Travel Distance

R = Drag Chain Bending Radius

H_1 = Mobile installation height

H_{D1} = Above the guide groove

h_a = Outer height of drag chain

ΔM = Distance from the mid-point of the fixed-end offset stroke

nR = Number of reverse installations on mobile

K_1 = Bend radius allowance

The K value can be found in the technical table of each drag chain series.

1. Reduce Installation Height of Moving End

In sliding applications, an excessively high moving end will cause an overlong suspended section and excessive installation angle, leading to easy breakage during retraction. Reducing the moving end height H_1 shortens the suspended length, relieves internal pressure, decreases the angle between the upper and lower chains, ensures stable operation, reduces wear and vibration, and prolongs service life.

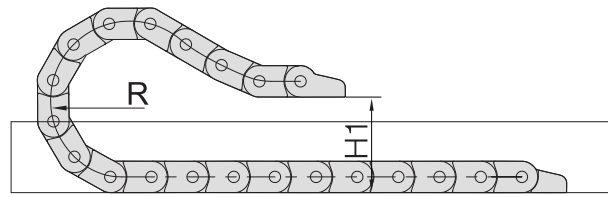

2. Reversed Mounting of Moving End Links

For drag chain sliding applications, several chain links at the moving end need to be reversely mounted in addition to height reduction. The number of reversed links nR is related to the drag chain type and bending radius R , which can be queried in the table of each series.

- Save installation space (reduce D_1 dimension)
- Form an S-shape at the moving end to reduce internal stress
- Prevent arching during operation

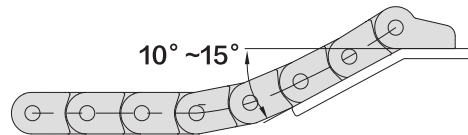
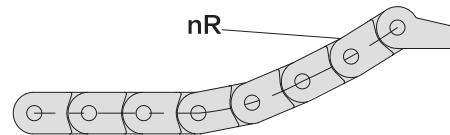
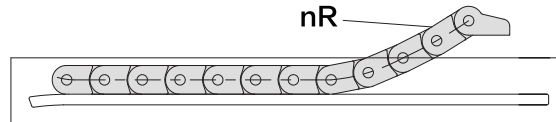

3. Moving End Connector and Support

In sliding applications, movable connectors are recommended as standard configuration to reduce the load on moving end links and avoid stress concentration.

It is recommended to support the first several links at the moving end to prevent overstress. The installation angle of the support plate is recommended to be 10° - 15° .

4. Guide Channel System

In sliding applications, a guide channel system is essential to achieve smoother operation and lower wear. The standard guide channel system consists of three parts: guide channel without wear strips, guide channel with wear strips and mounting kits. If the upper chain cannot slide on the lower chain smoothly, wear strips must be installed to reduce jumping and noise.

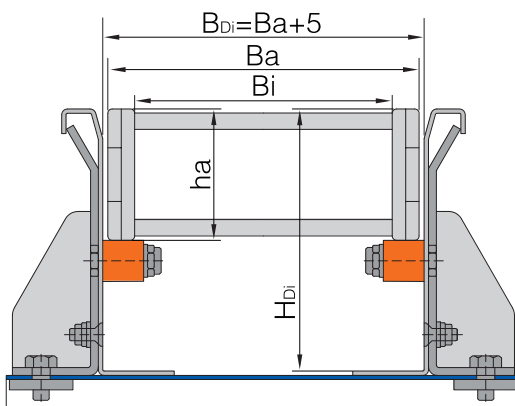

A) Guide channel without wear strip – The upper chain slides directly on the lower chain

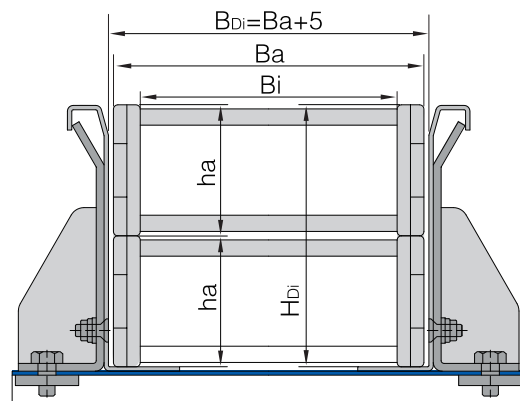

B) Guide channel with wear strip – The upper chain slides on wear strips starting from the mid-travel position

Vertical Application | Suspended | Upright

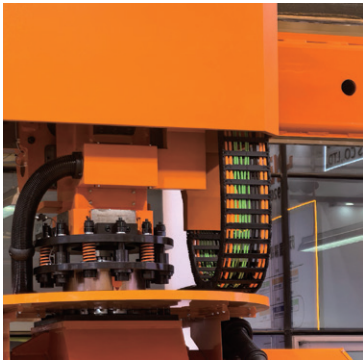

Upright Application

The drag chain runs vertically with its bending radius section arched upward. In upright installation, the drag chain bears its own weight as well as the load of internal cables and hoses. Due to the risk of lateral tipping, the travel distance is usually short.

Precautions

Connector-Fixed connectors are recommended as the standard configuration for vertical upright installation. Fixed connectors prevent the drag chain from swinging during movement.

Preload-For vertical upright installation, standard pre-tension drag chains are preferred with sufficient space. Non-pre-tension styles are available upon request for limited space.

Support-With lateral acceleration in vertical motion, lateral support baffles are required to avoid swing. Partial support is allowed, with baffles mandatory at swing areas.

Cable Clamp-For vertically upright drag chains, cable clamps and stress relief components shall be fitted at both ends to isolate gravity and extra tension on internal lines.

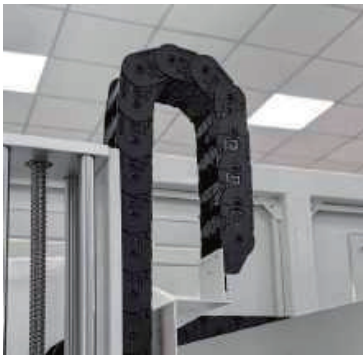

Suspended Application

The drag chain runs vertically with its bending radius section arched downward. Vertical suspension is a common mounting method in construction machinery, gantry manipulators, logistics warehousing and other industries. Under this working condition, the drag chain only arranges pipelines without bearing the weight of internal cables, so the travel distance can reach hundreds of meters.

Precautions

Connector-Fixed connectors are recommended as the standard configuration for vertical suspended installation.

Preload-For vertical suspended installation, drag chains with standard pre-tension are recommended if space allows. Please contact us for non-pre-tension drag chains if space is limited.

Support-If lateral acceleration occurs during vertical movement, lateral support baffles are recommended to prevent swinging. Partial lateral support is acceptable, and baffles must be installed at the swinging position of the drag chain.

Cable Clamp-When the drag chain is suspended vertically, cable clamps and other stress relief parts shall be installed at both ends to avoid gravity and extra tension on internal pipelines, preventing pipeline wear and core breakage in long-travel operation.



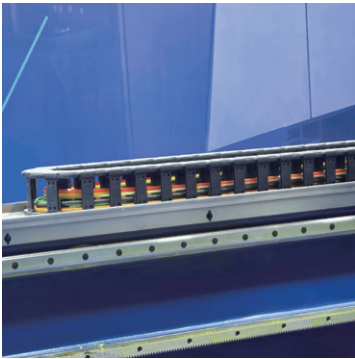

Side Mount Application

Side Mount Application: The drag chain is mounted sideways and performs horizontal linear reciprocating motion. Side mounting is adopted when installation height is restricted. In lateral linear operation, the drag chain can work overhead for short travel or slide for long travel, depending on support structures and guide grooves.

Precautions

Connector-Fixed connectors are recommended as the standard configuration for side installation. Fixed connectors effectively reduce swing during operation.

Pipeline Separation and Arrangement-For side-mounted drag chains, vertical dividers are recommended. Arrange pipelines with light components on the top and heavy ones at the bottom to enhance stability.

Bottom Support-Short-travel and low-load side installation allows overhead use. Full or partial support is required for long travel or heavy load conditions.

Equipped with complete guiding devices, side-mounted drag chains can achieve longer travel. Roller type structures are available for heavy-load and high-speed working conditions.

In practical application: Wider chain width and smaller bending radius allow longer overhead length; higher load will shorten the allowable overhead distance.

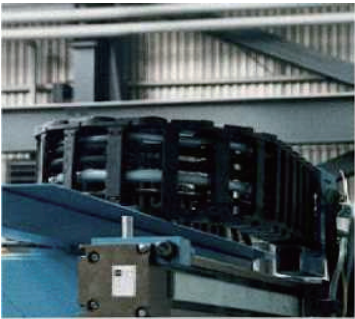

Rotary Application

Rotary Installation: The drag chain is mounted sideways and performs horizontal rotary reciprocating motion. Drag chains with reverse bending radius (S-bend) can rotate at a certain angle along inner or outer tracks.

Precautions

Connector-Movable connectors are the standard choice for rotary application, which can better adapt to circular operating tracks.

Pipeline Separation and Arrangement-The drag chain can rotate along inner or outer tracks. Custom structural design is available upon consultation.

Pipeline Arrangement-Vertical dividers are necessary for side installation. Reasonable weight distribution (light on top, heavy on bottom) ensures stable operation.



Separation Principle | Cables and Hoses

Separation Principle

Cables and hoses inside the drag chain shall be arranged evenly with reserved surrounding clearance for free movement. No tensile stress shall be generated at bending positions to avoid winding, abrasion and extrusion, which affect the service life of pipelines and the drag chain. The basic separation principles are as follows:

Principle 1: Cables and hoses with different outer sheath materials shall be separated by dividers.

Round cables – Arrange separately if installation space permits.

Flat cables – Use vertical dividers for side-by-side arrangement and horizontal dividers for stacking.

Air hoses – Refer to the layout rules for round cables; extra clearance is recommended for rubber hoses to prevent adhesion.

Hydraulic hoses – Expand and contract with pressure changes, so sufficient internal space must be reserved inside the drag chain.

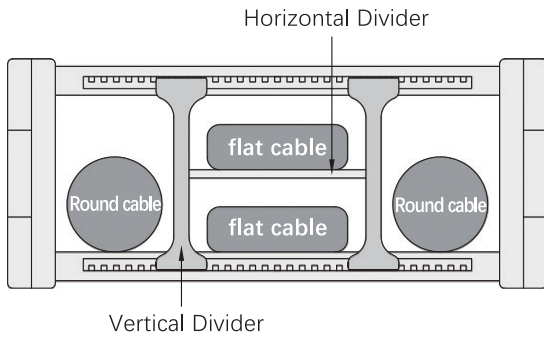

Weight Distribution

■ Horizontal or vertical installation: The weight of cables and hoses shall be symmetrically distributed along the drag chain width. Otherwise, unilateral abrasion will be aggravated and shorten the service life. Heavy pipelines shall be placed on both sides.

■ Lateral installation: Arrange cables and hoses from heavy to light in vertical order to prevent drag chain tipping.

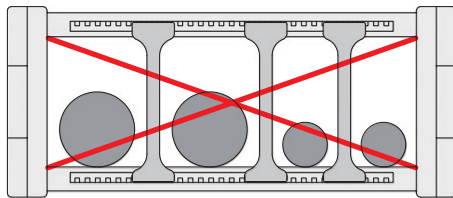

Unfavorable Weight Distribution

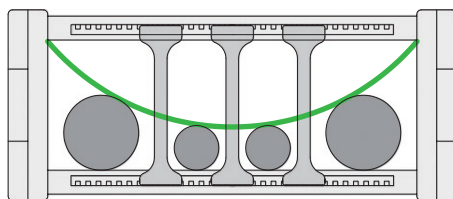

Favorable Weight Distribution

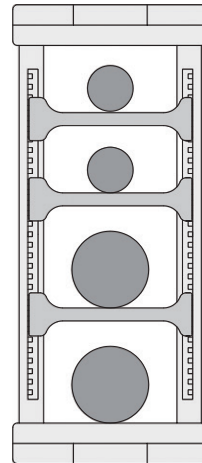

Favorable Weight Distribution

Pipeline Clearance

- Round Cable: 10% of outer diameter
- Flat Cable : 10% of width and thickness
- Hydraulic Hose : 20% of outer diameter
- Air Hose : 5-10% of outer diameter
- Media Hose : 15-20% of outer diameter

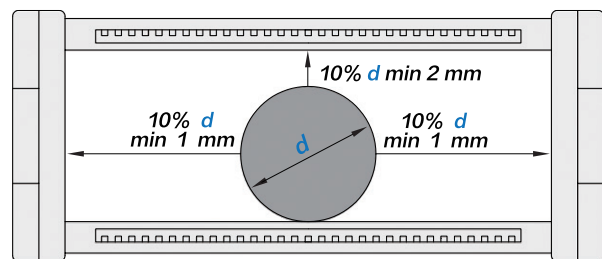

Clearance around round cables

Important: The internal filling rate of the drag chain shall not exceed 80%!

Multi-pipe Separation Principle

$$d1+d2 > 1.2 \cdot hi$$

When the sum of the diameters of parallel cables and conduit exceeds 1.2 times the inner height h of the drag chain, it is not necessary to use dividers.

$$d3+d4 \leq 1.2 \cdot hi$$

Or horizontal dividers shall be adopted to reduce the effective internal height.

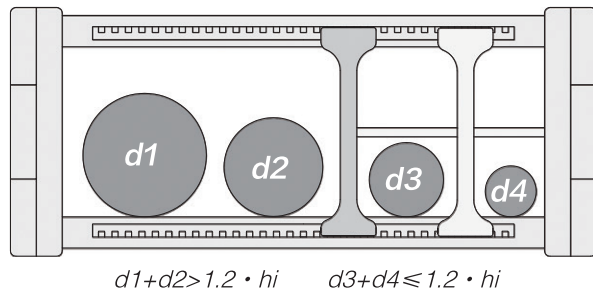

The bending radius of the drag chain is determined by the thickest or stiffest internal cable or hose, and shall comply with the minimum allowable bending radius of all pipelines. The drag chain bending radius shall be larger than the minimum bending radius of internal pipelines to prevent tensile abrasion at bending sections and improve pipeline service life.

$$d1 > 0.5 \cdot d2$$

Allowable stacking of two cables

$$d3 \leq 0.5 \cdot d2$$

Horizontal dividers are mandatory for stacked cables

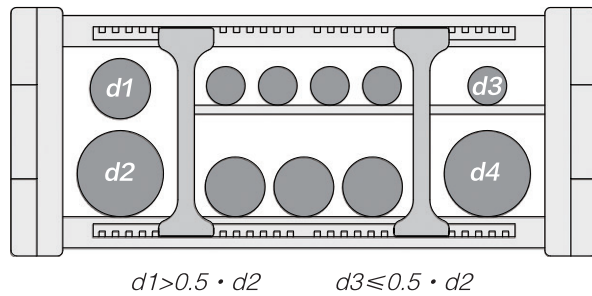

Bending Radius

The bending radius of the drag chain is determined by the thickest or stiffest internal cable or hose, and shall comply with the minimum allowable bending radius of all pipelines. The drag chain bending radius shall be larger than the minimum bending radius of internal pipelines to prevent tensile abrasion at bending sections and improve pipeline service life.

Micro 07 Series

Micro | W Series | Product Range

Compact Space



Drag Chain | W Series | One-piece non-openable

Product Code Drag Chain	Bi [mm]	Ba [mm]	R [mm]	Weight [kg/m]
W.07.07.R	7	12.3	015 018 028 038 048	≈0.07

Complete the model number according to the required bending radius (R), Example: W.07.07.R.015

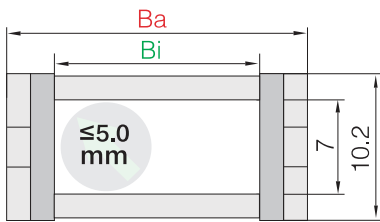

Inner [mm]	7
Height Pitch [mm/link]	16.9
Number /m	60
= [mm]	1014
Chain Length	$L_k = \frac{S}{2} + K$

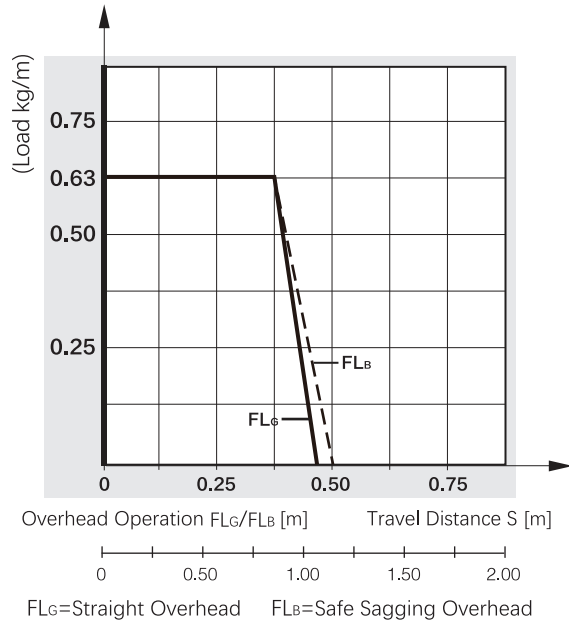

Overhead Application | Short Travel

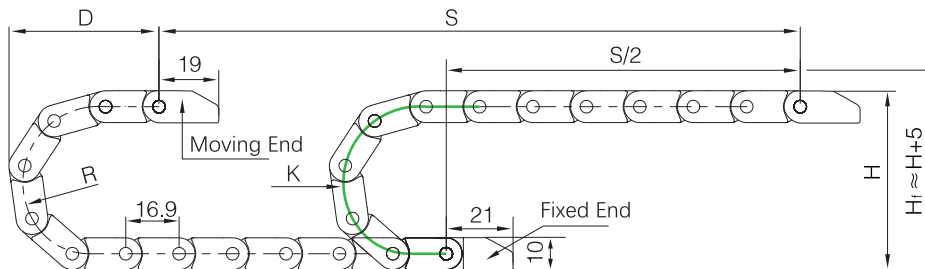

R	015	018	028	038	048
H	40	46	66	86	106
D	46	49	59	69	79
K	85	90	122	153	185

Actual Installation Height: $H_f \approx H+5\text{mm}$

Micro | W Series | Installation Dimensions

Micro Series

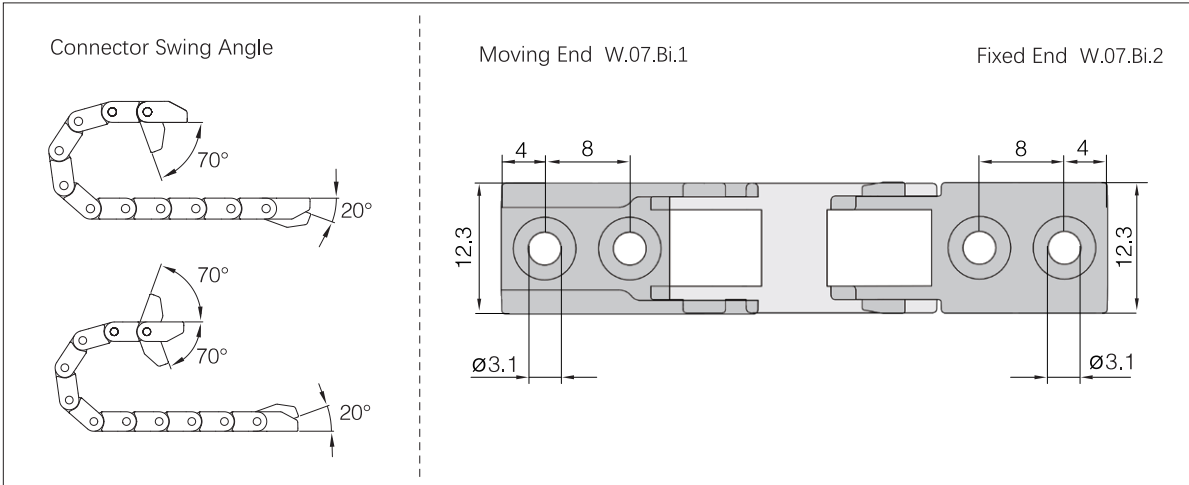

Ordering Example

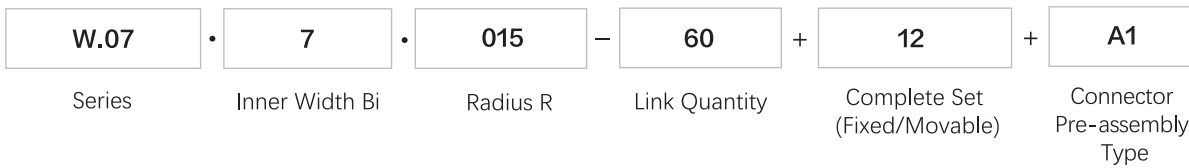

W.07Series Default Mounting Type: A1

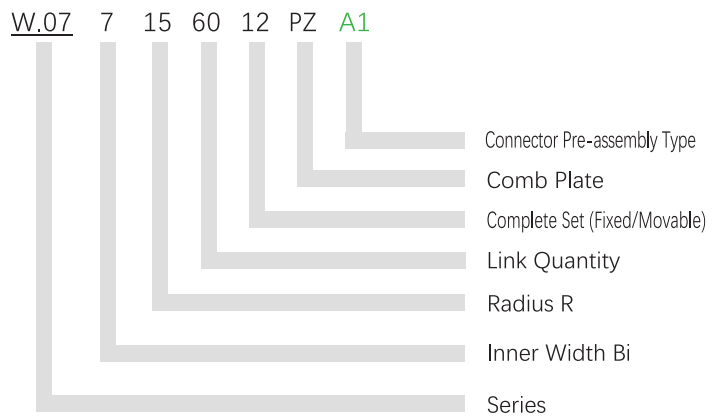
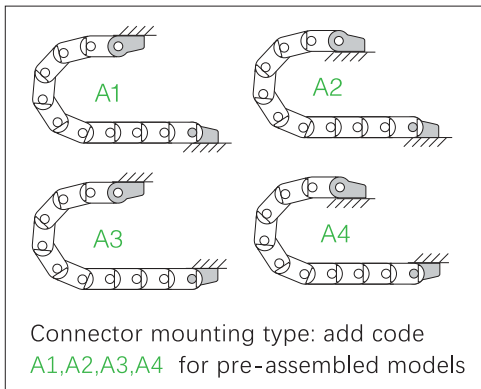

Micro 10 Series

Micro | W Series | Product Range

Compact Space



Drag Chain | W Series | One-piece semi-enclosed non-openable

Product Code Drag Chain	Bi [mm]	Ba [mm]	R [mm]	Weight [kg/m]
W.10.10.R	10	17.5	028	≈ 0.16
W.10.15.R	15	22.5	028	≈ 0.16
W.10.20.R	20	27.5	028	≈ 0.17

Complete the model number according to the required bending radius (R), Example: W.10.10.R.028

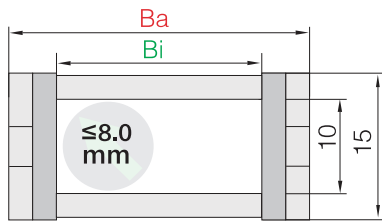

Inner [mm]	10
Height Pitch [mm/link]	20
Number /m	50
= [mm]	1000
Chain Length	$L_K = \frac{S}{2} + K$

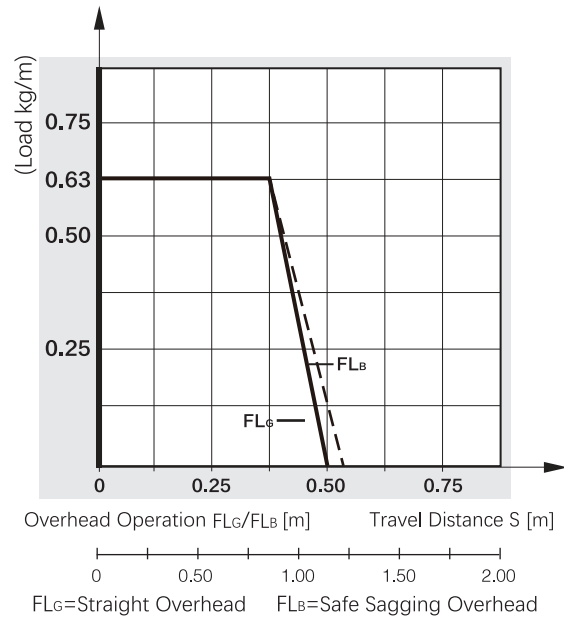

Overhead Application | Short Travel

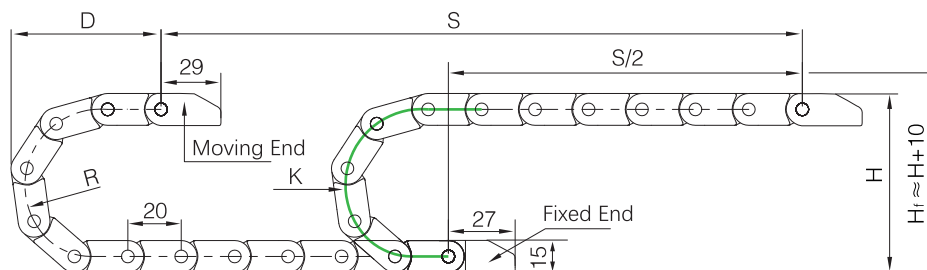

R	028
H	68
D	64
K	130

Actual Installation Height: $H_f \approx H + 10\text{mm}$

Micro | W Series | Installation Dimensions

Micro Series

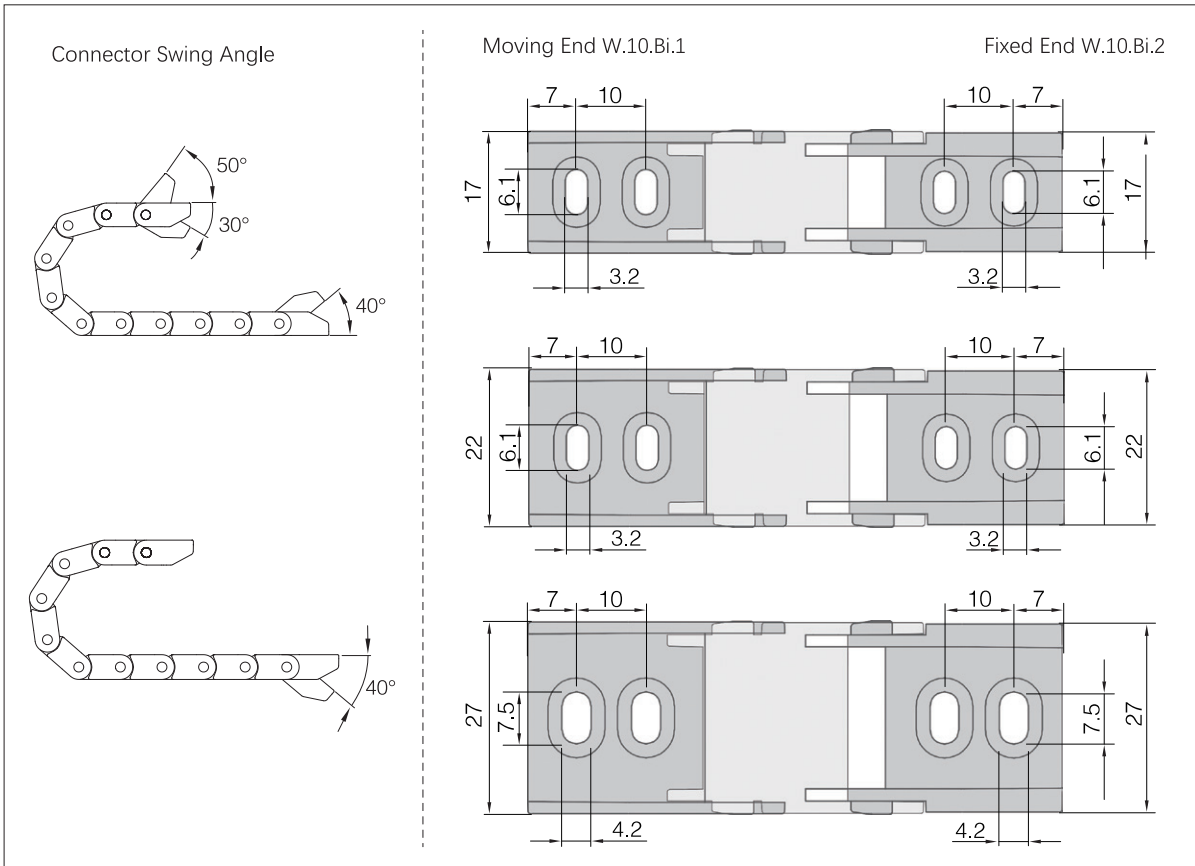

Ordering Example

W.10	•	10	•	028	-	60	+	12	+	A1
Series		Inner Width Bi		Radius R		Link Quantity		Complete Set (Fixed/Movable)		Connector Pre-assembly Type

W.10 Series

Default Mounting Type: A1

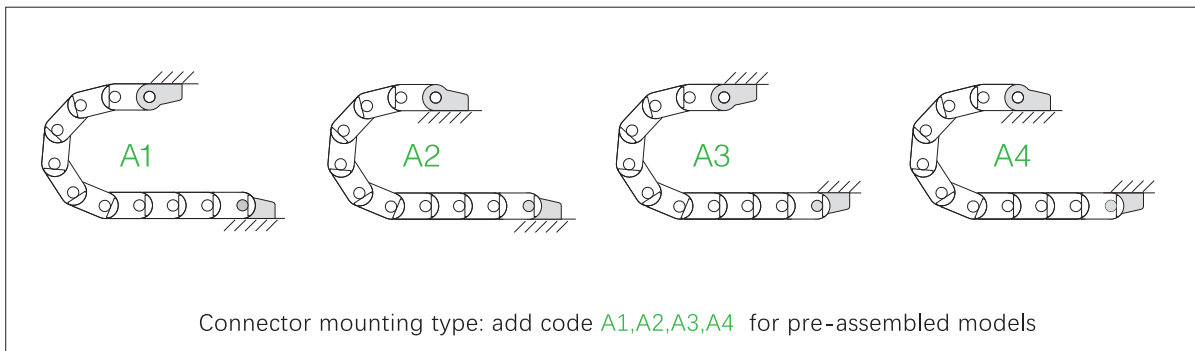

www.jinaobellowscover.com
www.czshenghao.com

Compact Size 15 Series

Compact Size | B Series | Product Range

Quick opening Easy assembly & Disassembly



Drag Chain | B Series | Open along inner bending radius



Product Code Drag Chain	Bi [mm]	Ba [mm]	R [mm]	Weight [kg/m]
B.15.15.R	15	25	028 038 048	≈ 0.25
B.15.20.R	20	30	028 038 048	≈ 0.27
B.15.30.R	30	40	028 038 048	≈ 0.30
B.15.40.R	40	50	028 038 048	≈ 0.33

Drag Chain | B Series | Open along outer bending radius



Product Code Drag Chain	Bi [mm]	Ba [mm]	R [mm]	Weight [kg/m]
B.15i.15.R	15	25	038 048	≈ 0.25
B.15i.20.R	20	30	038 048	≈ 0.27
B.15i.30.R	30	40	038 048	≈ 0.30
B.15i.40.R	40	50	038 048	≈ 0.33

Complete the model number according to the required bending radius (R), Example: B.15.15.R.028

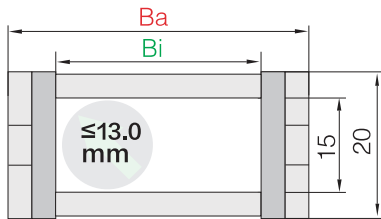

Inner [mm]	15
Height Pitch [mm/link]	25
Number /m	40
= [mm]	1000
Chain Length	$L_k = \frac{S}{2} + K$

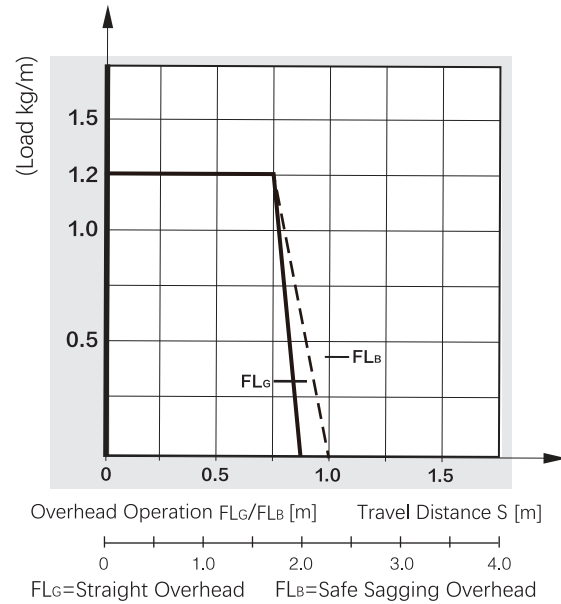

Overhead Application | Short Travel

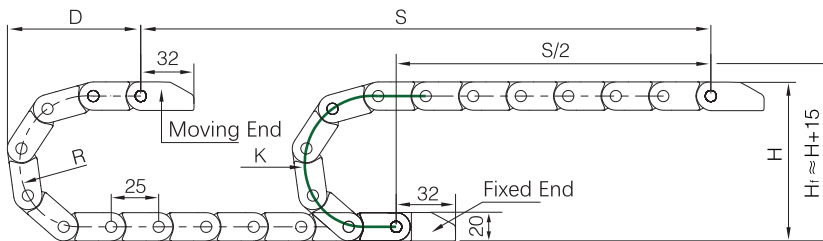

R	028	038	048
H	71	91	111
D	78	88	98
K	138	170	200

Actual Installation Height: $H_f \approx H + 15\text{mm}$

Compact Size | B Series | Installation Dimensions

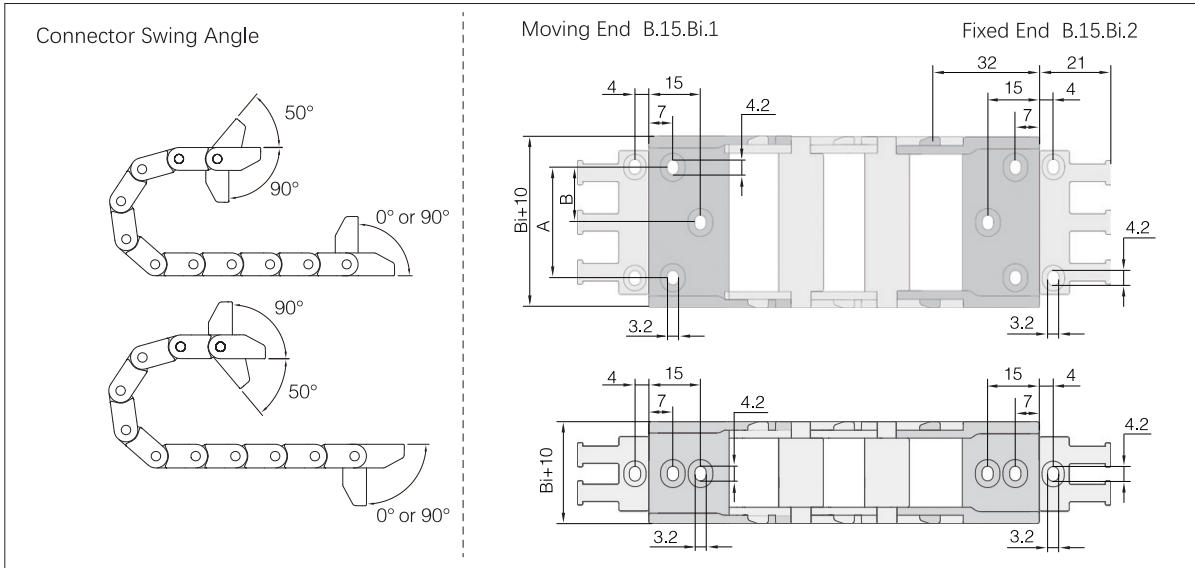

Product Code Complete set with comb plate	Product Code Complete set without comb plate	A [mm]	B [mm]	Bi [mm]	Number of teeth
B.015.015.12.PZ	B.015.015.12	--	--	15	1
B.015.020.12.PZ	B.015.020.12	--	--	20	2
B.015.030.12.PZ	B.015.030.12	15	7.5	30	3
B.015.040.12.PZ	B.015.040.12	32	16	40	3

Ordering Example

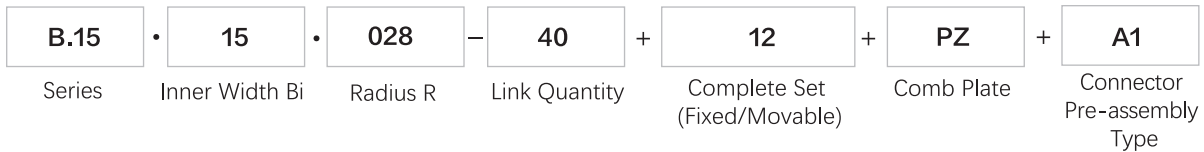

W.15 Series

Default Mounting Type: **A1**

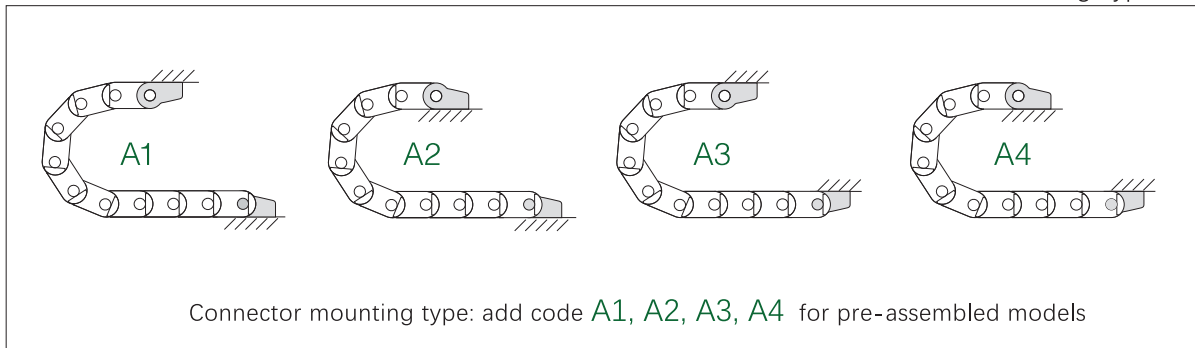

Compact Size 18 Series

Compact Size | B Series | Product Range

Quick opening Easy assembly & Disassembly



Drag Chain | B Series | Open along inner bending radius

Product Code Drag Chain	Bi [mm]	Ba [mm]	R [mm]	Weight [kg/m]
B.18.18.R	18	28	028 038 048 060 075	≈ 0.32
B.18.25.R	25	35	028 038 048 060 075	≈ 0.35
B.18.38.R	38	48	028 038 048 060 075	≈ 0.42
B.18.50.R	50	60	028 038 048 060 075	≈ 0.45

Complete the model number according to the required bending radius (R), Example: B.18.18.R.028

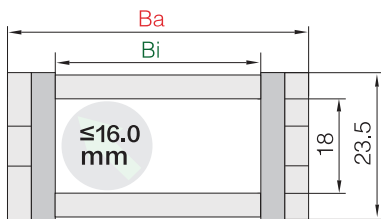

Inner [mm]	18
Height Pitch [mm/link]	30.5
Number /m	33
= [mm]	1006.5
Chain Length	$L_K = \frac{S}{2} + K$

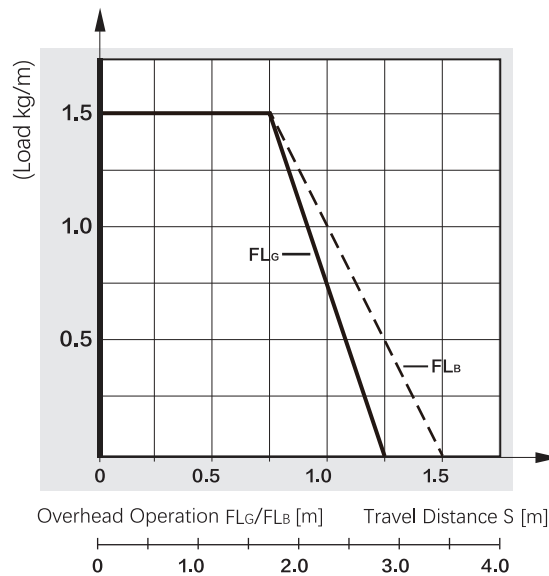

Overhead Operation FL_G/FL_B [m] Travel Distance S [m]
 FL_G =Straight Overhead FL_B =Safe Sagging Overhead

Overhead Application | Short Travel

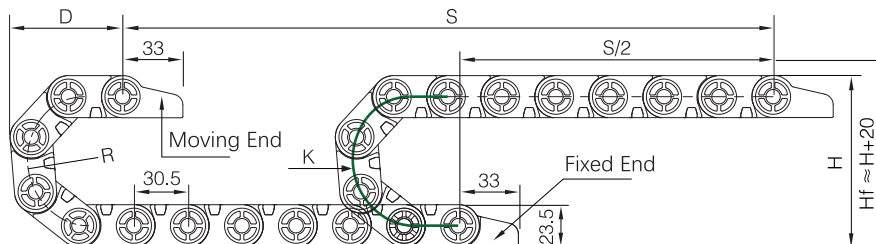

R	028	038	048	060	075
H	80	100	120	144	174
D	89	99	109	121	136
K	150	185	216	254	300

Actual Installation Height: $H_f \approx H + 20$ mm

Compact Size | B Series | Installation Dimensions

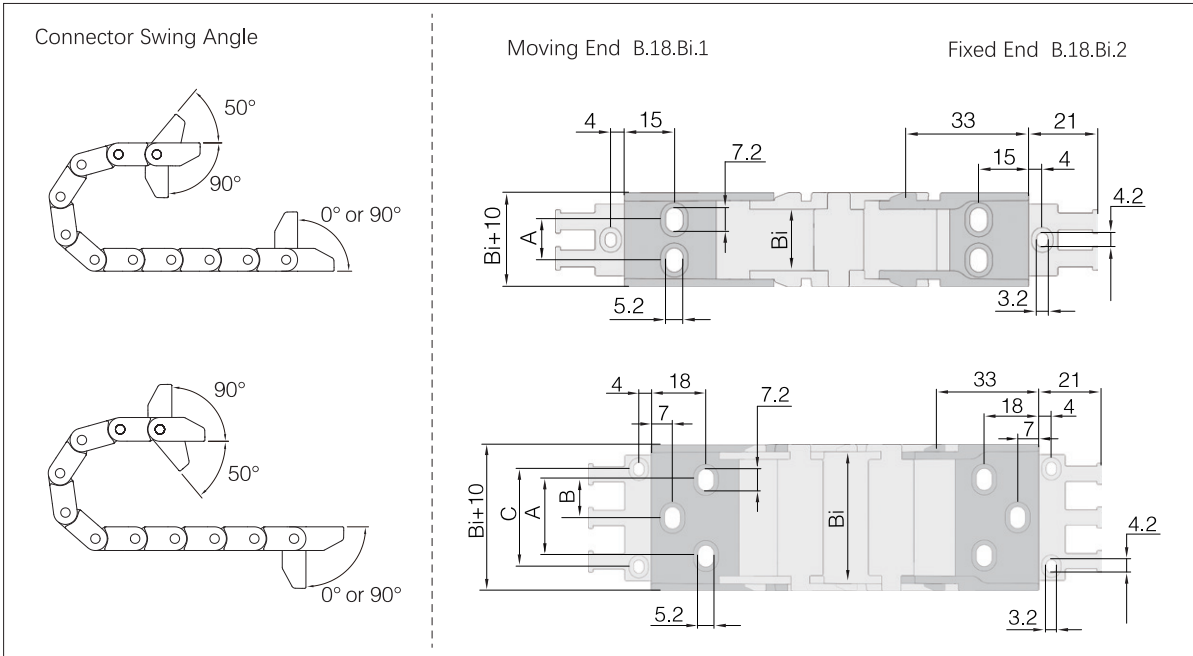

Movable Connector | Recommended for overhead and sliding applications

Fixed Connector | Recommended for vertical suspended and upright applications

Product Code Complete set with comb plate	Product Code Complete set without comb plate	A [mm]	B [mm]	C [mm]	Bi [mm]	Number of teeth
B.018.018.12.PZ	B.018.018.12	12	--	--	18	2
B.018.025.12.PZ	B.018.025.12	15.8	7.9	15.8	25	2
B.018.038.12.PZ	B.018.038.12	25	12.5	32	38	3
B.018.050.12.PZ	B.018.050.12	35	17.5	35	50	4

Ordering Example

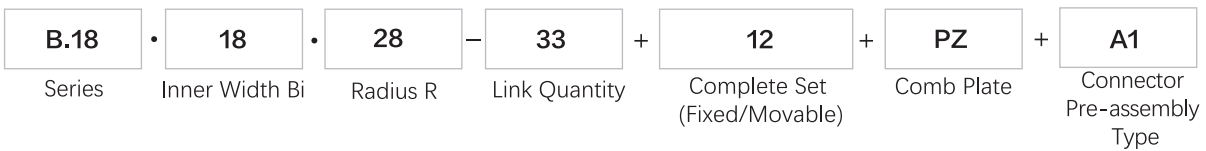

W.18 Series

Default Mounting Type: A1

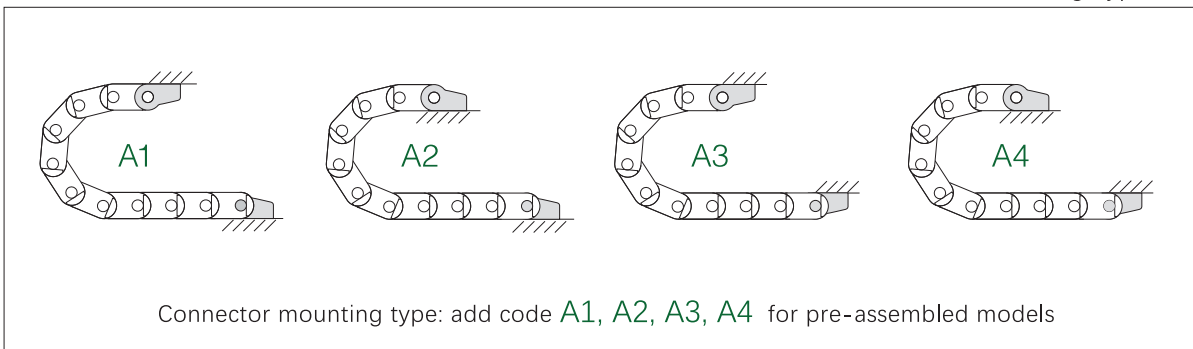

Compact Size 25 Series

Compact Size | B Series | Product Range

Quick opening Easy assembly & Disassembly

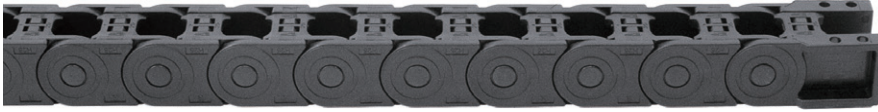

Drag Chain | B Series | Open along inner bending radius

Product Code Drag Chain	Bi [mm]	Ba [mm]	R [mm]	Weight [kg/m]
B.25.25.R	25	40	038 055 075 --	≈ 0.86
B.25.38.R	38	53	038 055 075 100	≈ 0.93
B.25.57.R	57	72	038 055 075 100	≈ 1.02
B.25.75.R	75	90	-- 055 075 100	≈ 1.04
B.25.100.R	100	115	038 055 075 100	≈ 1.17

Drag Chain | B Series | Open along outer bending radius

Product Code Drag Chain	Bi [mm]	Ba [mm]	R [mm]	Weight [kg/m]
B.25i.25.R	25	40	055 075 100	≈ 0.86
B.25i.38.R	38	53	055 075 100	≈ 0.93
B.25i.57.R	57	72	055 075 100	≈ 1.02
B.25i.75.R	75	90	055 075 100	≈ 1.04
B.25i.100.R	100	115	055 075 100	≈ 1.17

Complete the model number according to the required bending radius (R), Example: B.25.25.R.055

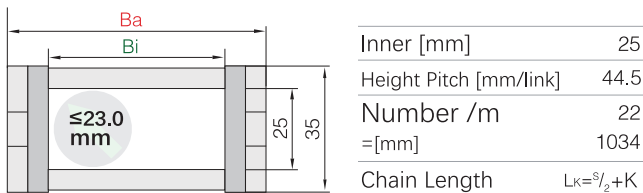

Overhead Application | Short Travel

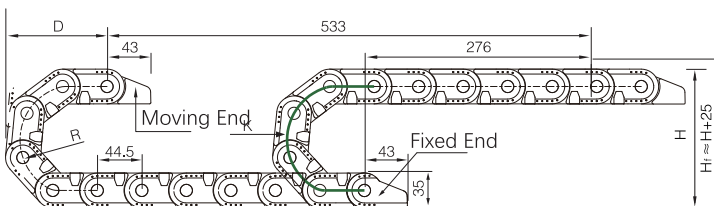

R	038	055	075	100
H	86	120	160	210
D	130	145	165	190
K	210	262	325	405

Actual Installation Height: $H_i \approx H + 25\text{mm}$

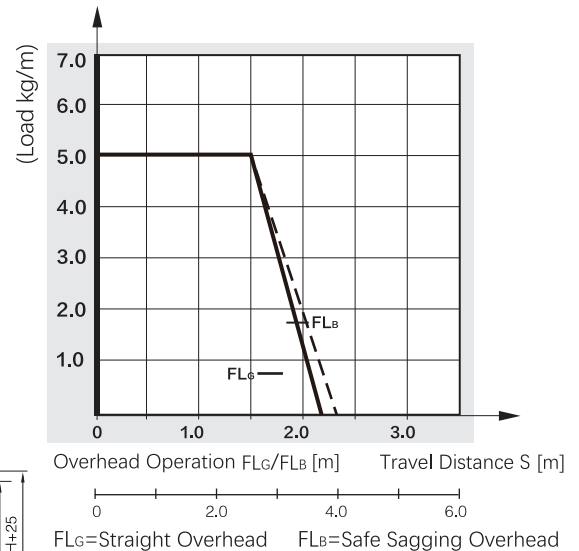

Compact Size | B Series | Installation Dimensions

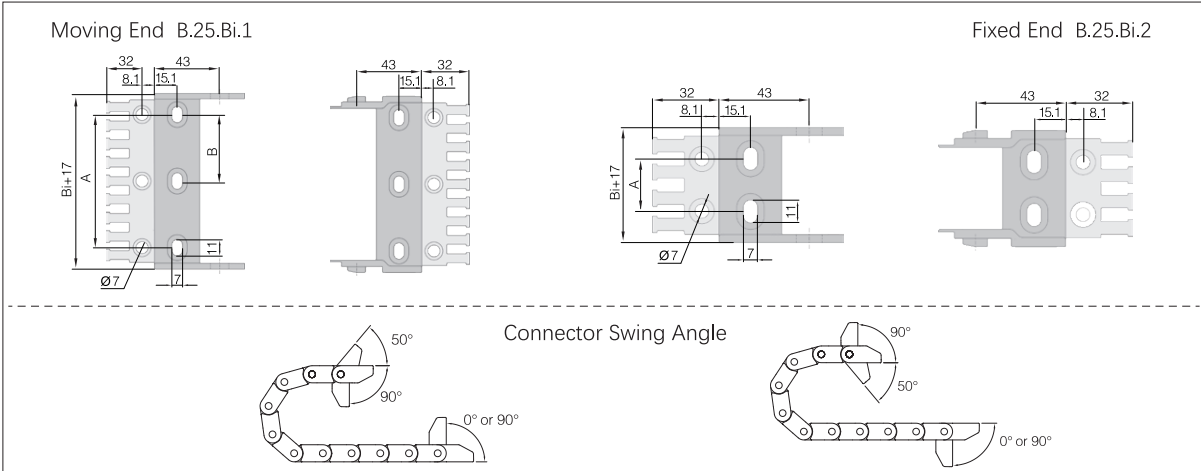

Product Code Complete set with comb plate	Product Code Complete set without comb plate	A [mm]	B [mm]	Bi [mm]	Number of teeth
B.025.025.12.PZ	B.025.025.12	15.8	--	25	3
B.025.038.12.PZ	B.025.038.12	25.2	--	38	4
B.025.057.12.PZ	B.025.057.12	46.8	--	57	6
B.025.075.12.PZ	B.025.075.12	60	--	75	8
B.025.100.12.PZ	B.025.100.12	88.6	44.3	100	9

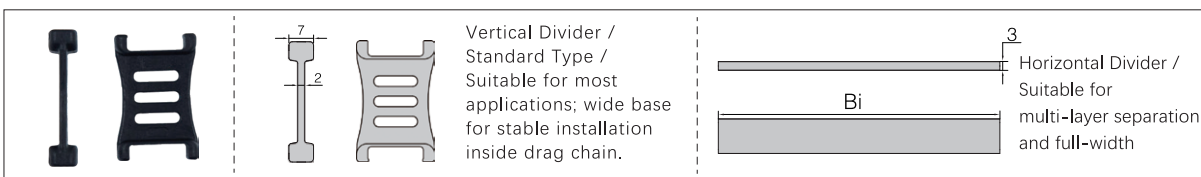
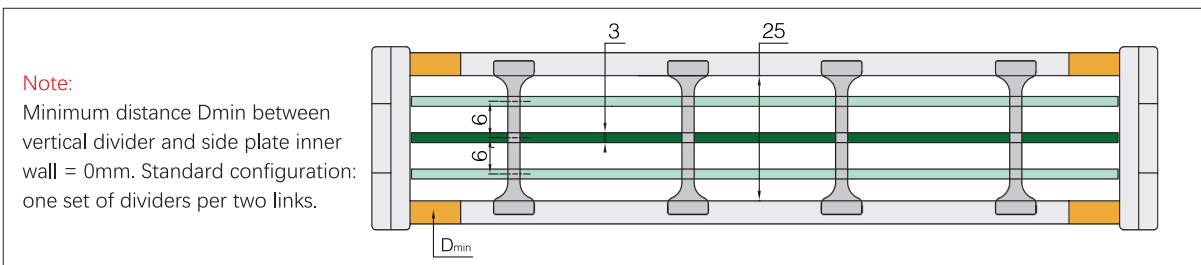

Ordering Example

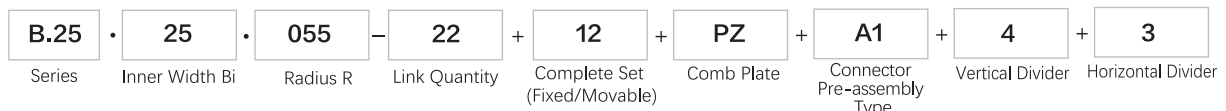

B.25 Series

Default Mounting Type: **A1**

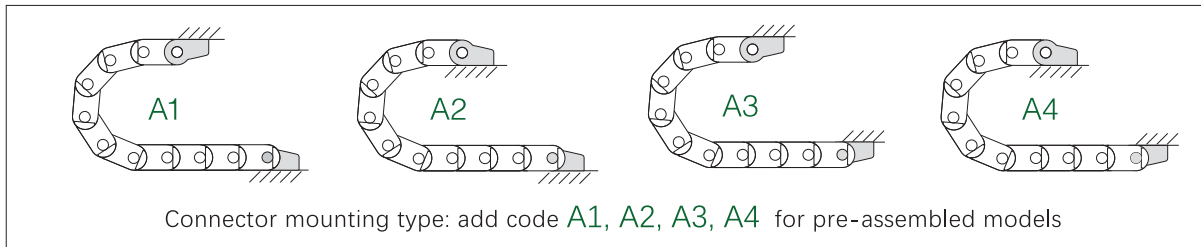

Compact Size Series

www.jinaobellowscover.com
www.czshenghao.com

Light Size | L Series | Product Range

Stable operation High versatility



Drag Chain | L Series | Bridge type, upper & lower cover openable

Product Code Drag Chain	Bi [mm]	Ba [mm]	R [mm]	Weight [kg/m]
L.25Q.25.R	25	40	055 075 100 125 150 175 190 200 250	≈0.86
L.25Q.38.R	38	53	055 075 100 125 150 175 190 200 250	≈0.93
L.25Q.50.R	50	65	055 075 100 125 150 175 190 200 250	≈1.02
L.25Q.57.R	57	72	055 075 100 125 150 175 190 200 250	≈1.04
L.25Q.75.R	75	90	055 075 100 125 150 175 190 200 250	≈1.21

Complete the model number according to the required bending radius (R), Example: L.25.25.R.055

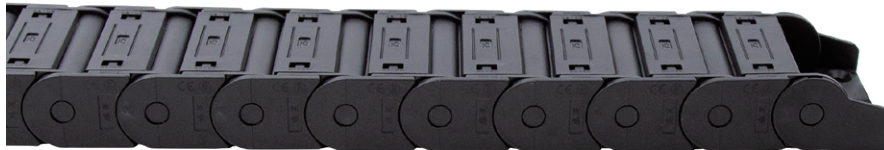

Drag Chain | L Series | Fully enclosed, upper & lower cover openable

Product Code Drag Chain	Bi [mm]	Ba [mm]	R [mm]	Weight [kg/m]
L.25F.25.R	25	40	055 075 100 125 150 175 190 200 250	≈0.75
L.25F.38.R	38	53	055 075 100 125 150 175 190 200 250	≈1.12
L.25F.50.R	50	65	055 075 100 125 150 175 190 200 250	≈1.25
L.25F.57.R	57	72	055 075 100 125 150 175 190 200 250	≈1.31
L.25F.75.R	75	90	055 075 100 125 150 175 190 200 250	≈1.61

Complete the model number according to the required bending radius (R), Example: L.25.25.R.055

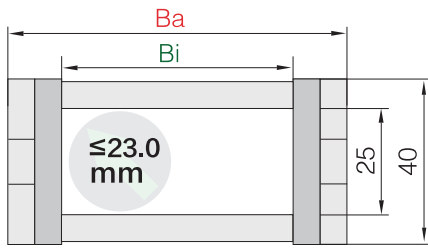

Inner [mm]	25
Height Pitch [mm/link]	47
Number /m	22
= [mm]	1034
Chain Length	$L_k = \frac{S}{2} + K$

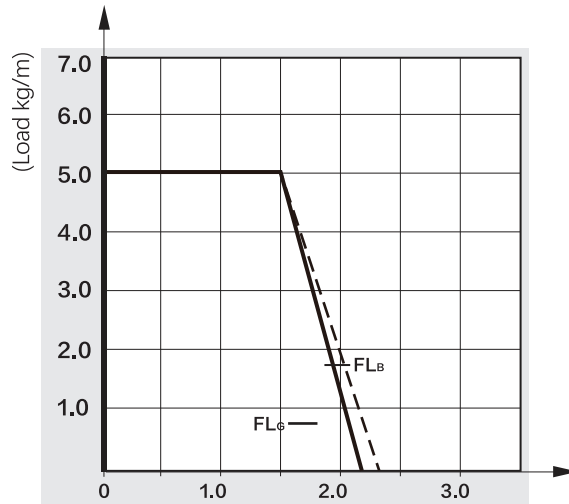

Overhead Operation FLG/FLB [m] Travel Distance S [m]

FLG= Straight Overhead FLB= Safe Sagging Overhead

Overhead Application | Short Travel

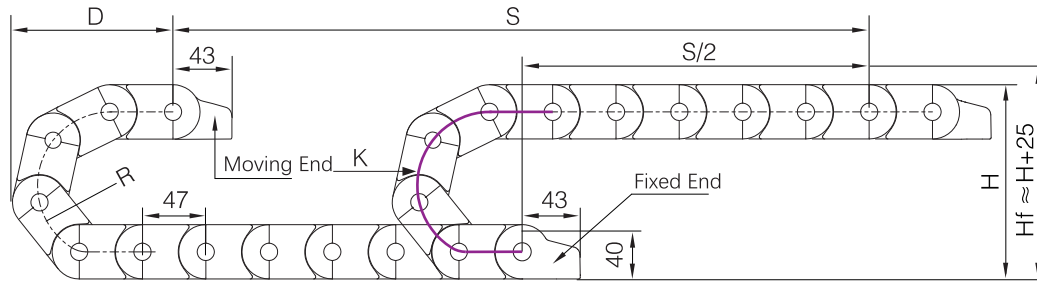

R	055	075	100	125	150	175	190	200	250
H	150	190	240	290	340	390	420	440	540
D	149	169	194	219	245	269	284	294	344
K	267	330	408	487	565	644	691	722	879

Actual Installation Height: $H_f \approx H + 25\text{mm}$

Sliding Application | Long Travels : $L_k = S/2 + K_1 + \Delta M$

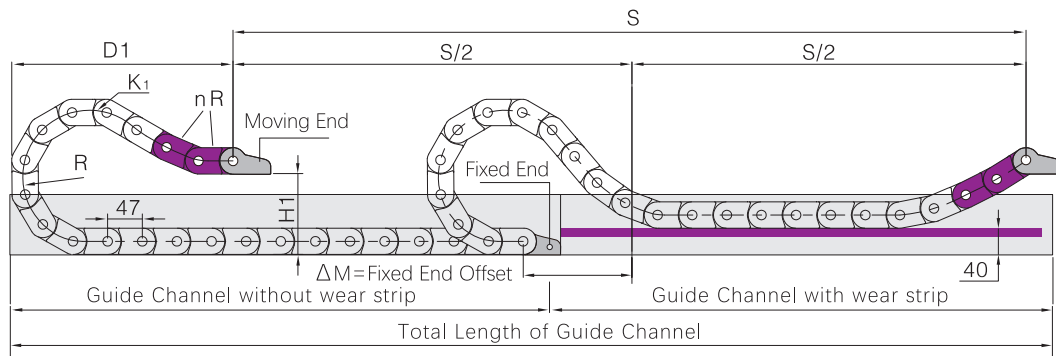

R	055	075	100	125	150	175	190	200	250
H _f	130	120	120	120	120	120	120	120	120
D ₁	146	260	380	445	590	755	770	950	1135
K ₁	265	415	645	736	1010	1250	1330	1470	1790
ΔC	--	115	210	240	365	495	580	675	800
nR	--	2	2	3	3	3	4	4	4

Light Size | L Series | Installation Dimensions

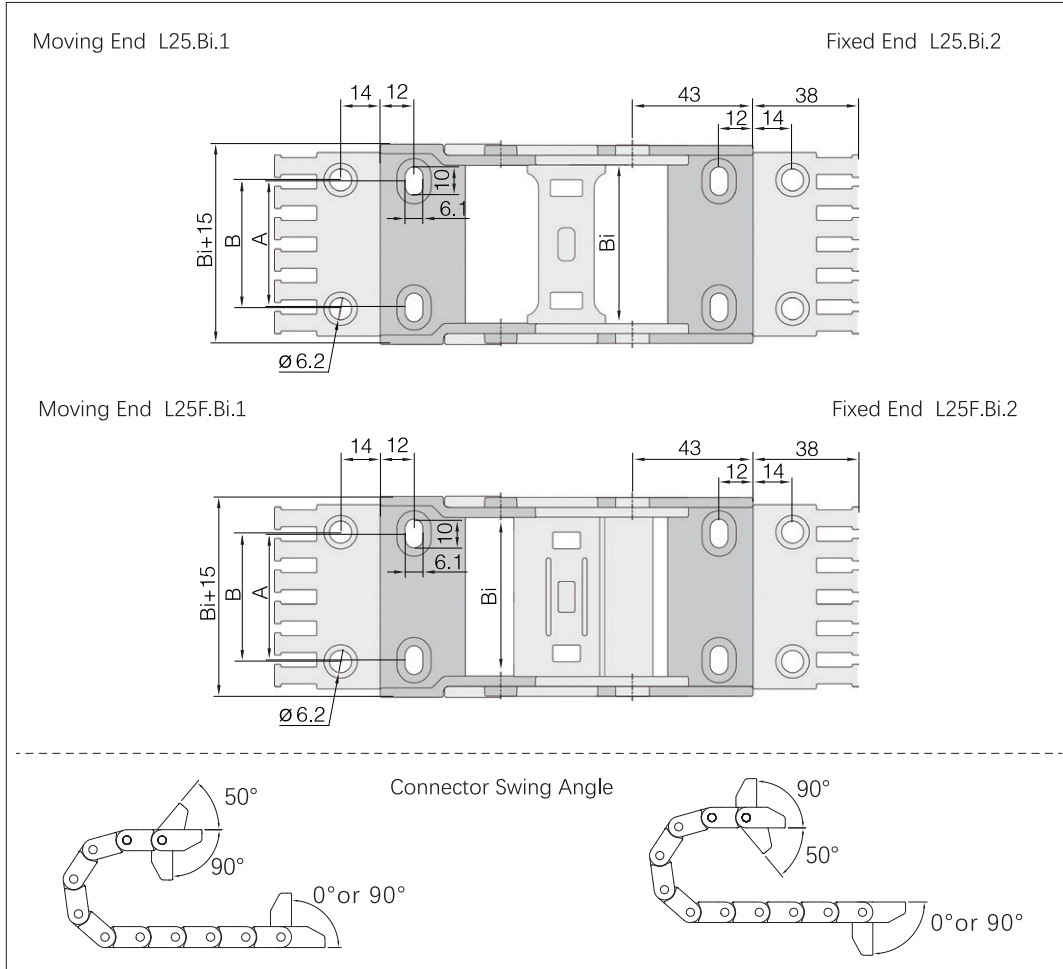

Product Code Complete set with comb plate	Product Code Complete set without comb plate	A [mm]	B [mm]	Bi [mm]	Number of teeth
L.025Q.025.12.PZ	L.025Q.025.12	14	15.8	25	3
L.025Q.038.12.PZ	L.025Q.038.12	25	25.2	38	4
L.025Q.050.12.PZ	L.025Q.050.12	37	31.6	50	6
L.025Q.057.12.PZ	L.025Q.057.12	45	46.8	57	6
L.025Q.075.12.PZ	L.025Q.075.12	63	60	75	8

Product Code Complete set with comb plate	Product Code Complete set without comb plate	A [mm]	B [mm]	Bi [mm]	Number of teeth
L.025F.025.12.PZ	L.025F.025.12	14	15.8	25	3
L.025F.038.12.PZ	L.025F.038.12	25	25.2	38	4
L.025F.050.12.PZ	L.025F.050.12	37	31.6	50	6
L.025F.057.12.PZ	L.025F.057.12	45	46.8	57	6
L.025F.075.12.PZ	L.025F.075.12	63	60	75	8

Separation Principle | Vertical Divider Horizontal Divider

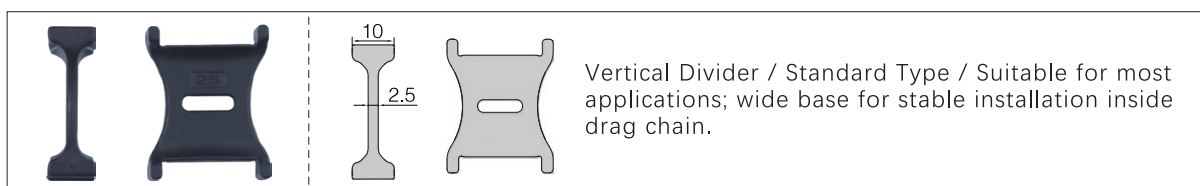
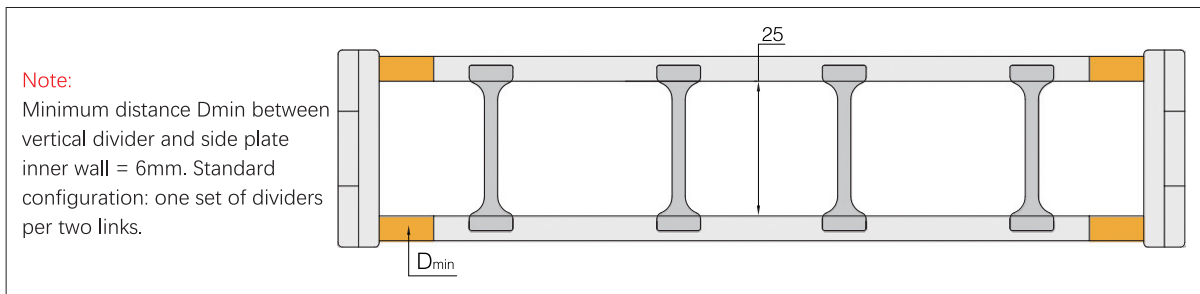

Ordering Example



L.25 Series Default Mounting Type: A1

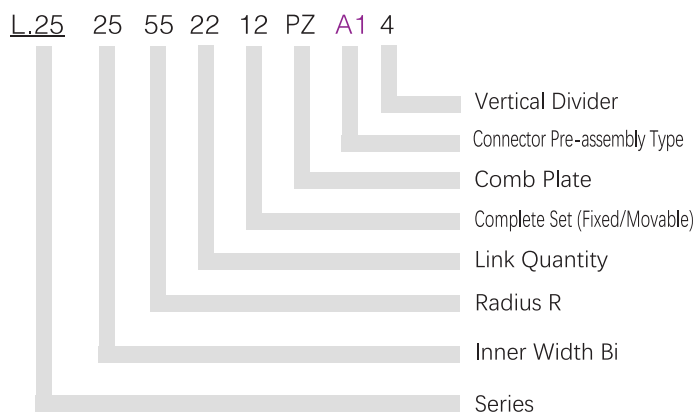
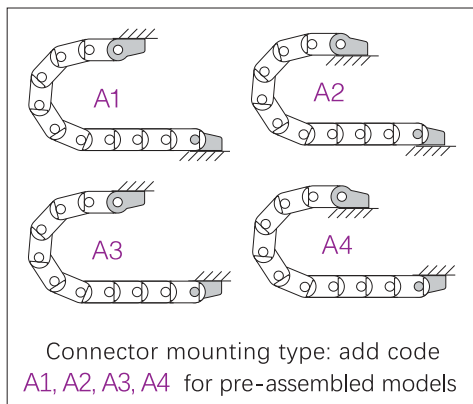

Light Size 35 Series

Light Size | L Series | Product Range

Stable operation High versatility



Drag Chain | L Series | Bridge type, upper & lower cover openable

Product Code Drag Chain	Bi [mm]	Ba [mm]	R [mm]	Weight [kg/m]
L.35Q.50.R	50	76	075 100 125 150 175 200 250 300	≈1.43
L.35Q.60.R	60	86	075 100 125 150 175 200 250 300	≈1.52
L.35Q.65.R	65	91	075 100 125 150 175 200 250 300	≈1.45
L.35Q.75.R	75	101	075 100 125 150 175 200 250 300	≈1.60
L.35Q.100.R	100	126	075 100 125 150 175 200 250 300	≈1.73
L.35Q.115.R	115	141	075 100 125 150 175 200 250 300	≈1.82
L.35Q.125.R	125	151	075 100 125 150 175 200 250 300	≈1.88
L.35Q.150.R	150	176	075 100 125 150 175 200 250 300	≈2.01
L.35Q.175.R	175	221	075 100 125 150 175 200 250 300	≈2.20
L.35Q.200.R	200	226	075 100 125 150 175 200 250 300	≈2.40
L.35Q.250.R	250	276	075 100 125 150 175 200 250 300	≈2.62

Complete the model number according to the required bending radius (R), Example: L.35.50.R.075



Drag Chain | L Series | Fully enclosed, upper & lower cover openable

Product Code Drag Chain	Bi [mm]	Ba [mm]	R [mm]	Weight [kg/m]
L.35F.50.R	50	76	075 100 125 150 175 200 250 300	≈1.65
L.35F.60.R	60	86	075 100 125 150 175 200 250 300	≈1.87
L.35F.65.R	65	91	075 100 125 150 175 200 250 300	≈1.90
L.35F.75.R	75	101	075 100 125 150 175 200 250 300	≈1.93
L.35F.100.R	100	126	075 100 125 150 175 200 250 300	≈2.23
L.35F.125.R	125	151	075 100 125 150 175 200 250 300	≈2.39
L.35F.150.R	150	176	075 100 125 150 175 200 250 300	≈2.79

Complete the model number according to the required bending radius (R), Example: L.35.50.R.075

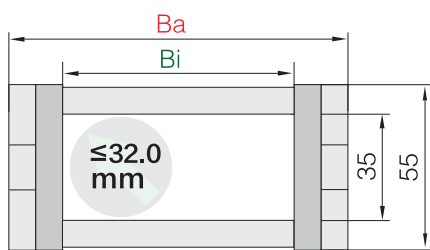

Inner [mm]	35
Height Pitch [mm/link]	67
Number /m	15
= [mm]	1005
Chain Length	$L_k = \frac{S}{2} + K$

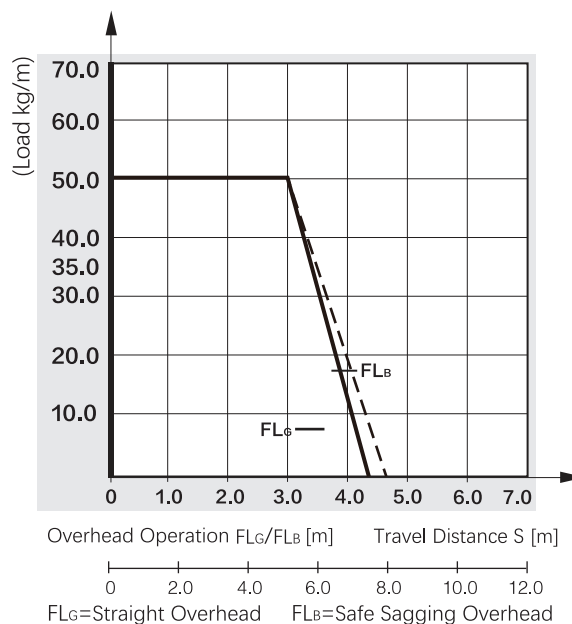

Overhead Application | Short Travel

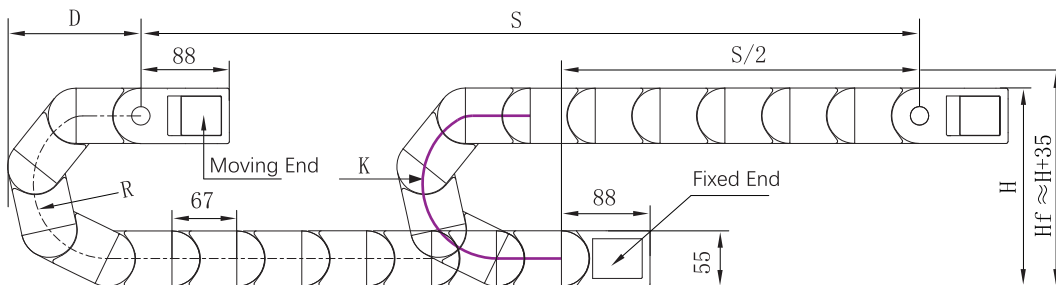

R	075	100	125	150	175	200	250	300
H	205	255	305	355	405	455	555	655
D	210	235	260	285	310	335	385	435
K	370	450	530	605	685	765	920	1080

Actual Installation Height: $H_f \approx H+35\text{mm}$

Sliding Application | Long Travels : $L_k = S/2 + K_1 + \Delta M$

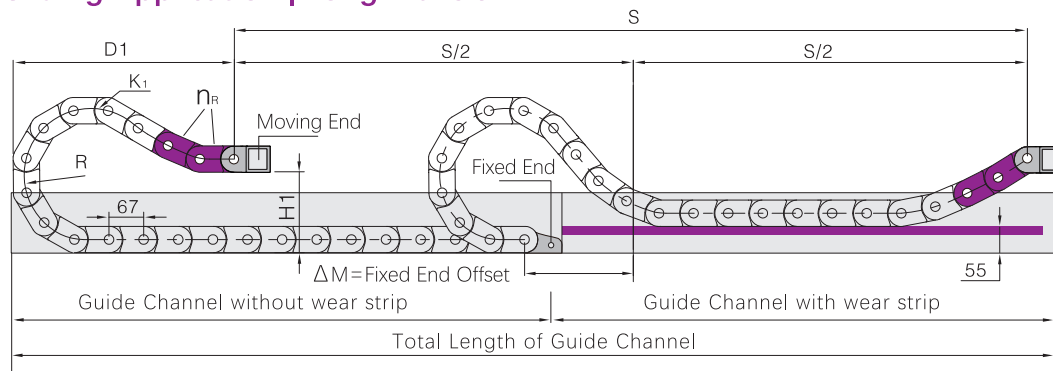

R	075	100	125	150	175	200	250	300
H_1	150	165	165	165	165	165	165	165
D_1	203	230	470	575	725	780	1015	1145
K_1	365	445	800	1000	1130	1335	1670	1940
ΔC	--	--	235	305	445	465	645	735
nR	--	--	2	2	2	3	3	4

Light Size | L Series | Installation Dimensions

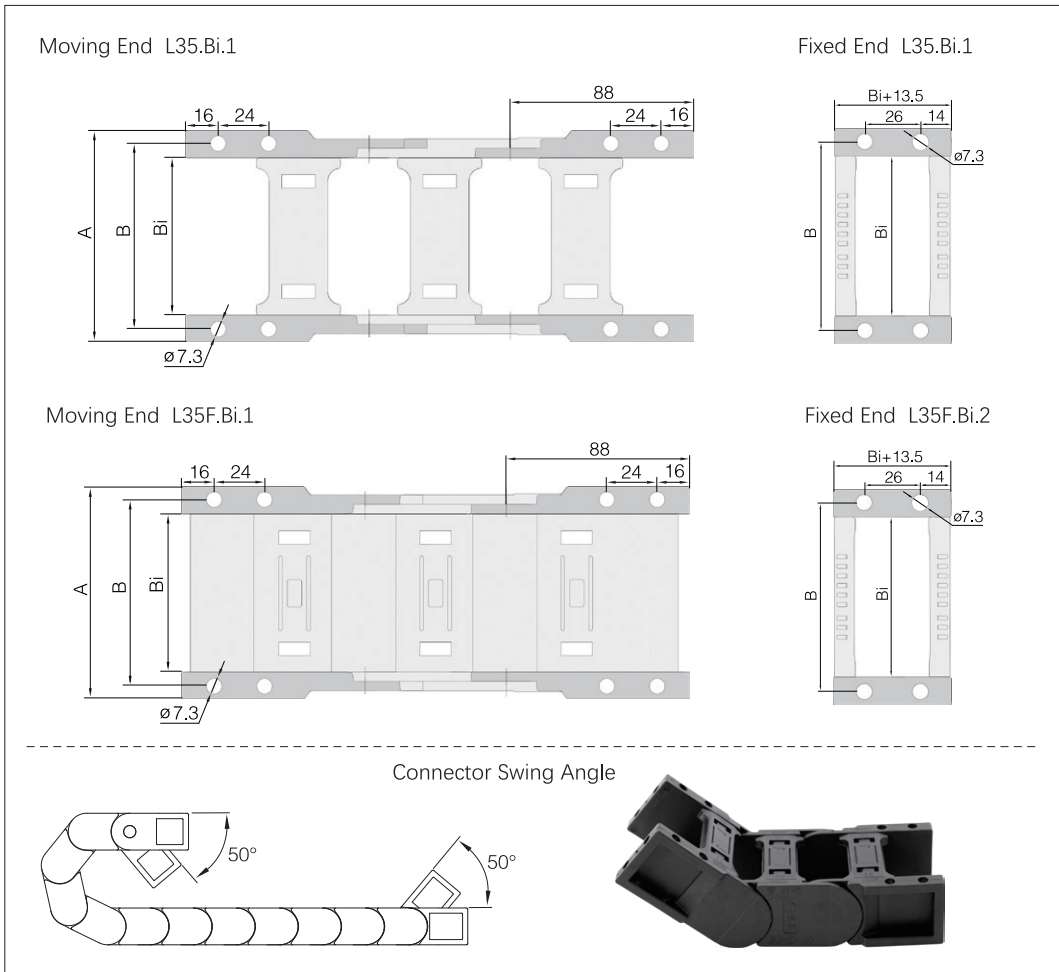

Product Code Complete Set	A [mm]	B [mm]	Bi [mm]
L.035Q.050.12	76	63.5	50
L.035Q.060.12	86	73.5	60
L.035Q.065.12	91	78.5	65
L.035Q.075.12	101	88.5	75
L.035Q.100.12	126	113.5	100
L.035Q.115.12	141	128.5	115
L.035Q.125.12	151	138.5	125
L.035Q.150.12	176	163.5	150
L.035Q.175.12	201	188.5	175
L.035Q.200.12	226	213.5	200
L.035Q.250.12	276	263.5	250

Product Code Complete Set	A [mm]	B [mm]	Bi [mm]
L.035F.050.12	76	63.5	50
L.035F.060.12	86	73.5	60
L.035F.065.12	91	78.5	65
L.035F.075.12	101	88.5	75
L.035F.100.12	126	113.5	100
L.035F.125.12	151	138.5	125
L.035F.150.12	176	163.5	150

Separation Principle | Vertical Divider Horizontal Divider

Note:

Minimum distance D_{min} between vertical divider and side plate inner wall = 11mm. Standard configuration: one set of dividers per two links.

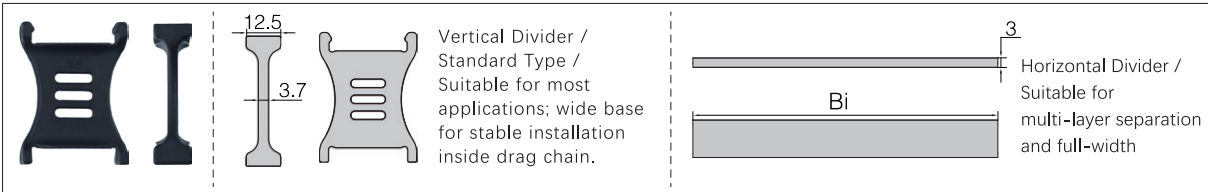
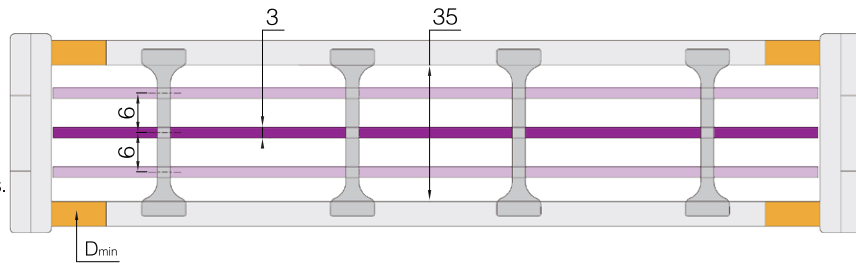

Ordering Example

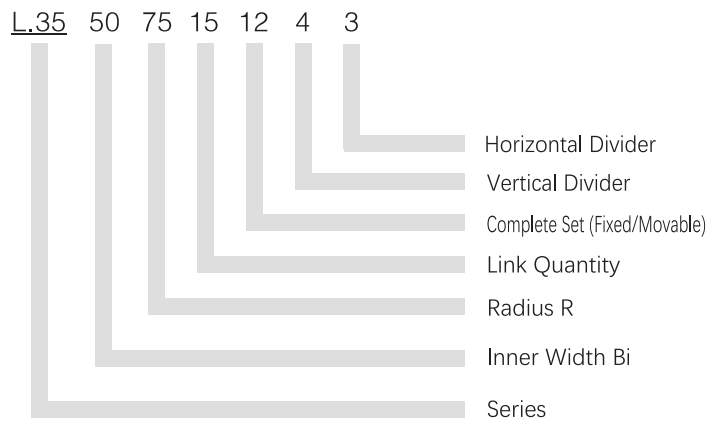
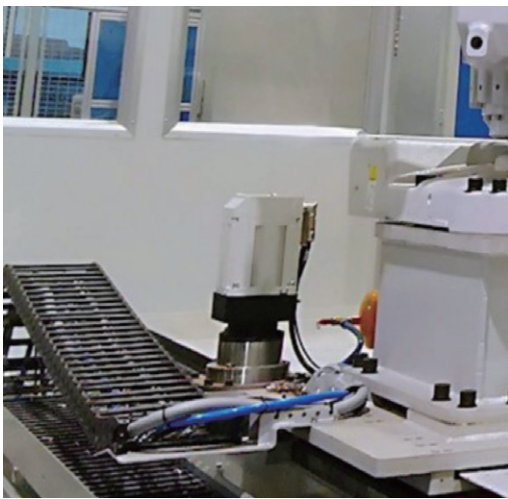
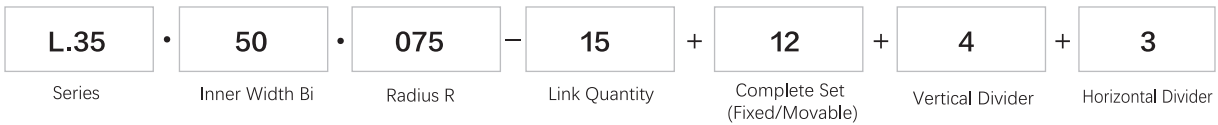

Full Black 35 Series

Full Black | H Series | Product Range

Tongue-and-groove structure High stability



Drag Chain | H Series | Bridge type, upper & lower cover openable

Product Code Drag Chain	Bi [mm]	Ba [mm]	R [mm]	Weight [kg/m]
H.35Q.50.R	50	76	075 100 125 150 175 200 250 300	≈ 1.64
H.35Q.60.R	60	86	075 100 125 150 175 200 250 300	≈ 1.72
H.35Q.65.R	65	91	075 100 125 150 175 200 250 300	≈ 1.64
H.35Q.75.R	75	101	075 100 125 150 175 200 250 300	≈ 1.80
H.35Q.100.R	100	126	075 100 125 150 175 200 250 300	≈ 1.93
H.35Q.115.R	115	141	075 100 125 150 175 200 250 300	≈ 1.95
H.35Q.125.R	125	151	075 100 125 150 175 200 250 300	≈ 2.09
H.35Q.150.R	150	176	075 100 125 150 175 200 250 300	≈ 2.21
H.35Q.175.R	175	201	075 100 125 150 175 200 250 300	≈ 2.27
H.35Q.200.R	200	226	075 100 125 150 175 200 250 300	≈ 2.60
H.35Q.250.R	250	276	075 100 125 150 175 200 250 300	≈ 2.95

Complete the model number according to the required bending radius (R), Example: H.35Q.50.R.075



Drag Chain | H Series | Fully enclosed, upper & lower cover openable

Product Code Drag Chain	Bi [mm]	Ba [mm]	R [mm]	Weight [kg/m]
H.35F.50.R	50	76	075 100 125 150 175 200 250 300	≈ 1.81
H.35F.60.R	60	86	075 100 125 150 175 200 250 300	≈ 2.02
H.35F.65.R	65	91	075 100 125 150 175 200 250 300	≈ 2.00
H.35F.75.R	75	101	075 100 125 150 175 200 250 300	≈ 2.13
H.35F.100.R	100	126	075 100 125 150 175 200 250 300	≈ 2.44
H.35F.125.R	125	151	075 100 125 150 175 200 250 300	≈ 2.57
H.35F.150.R	150	176	075 100 125 150 175 200 250 300	≈ 3.00

Complete the model number according to the required bending radius (R), Example: H.35F.50.R.075

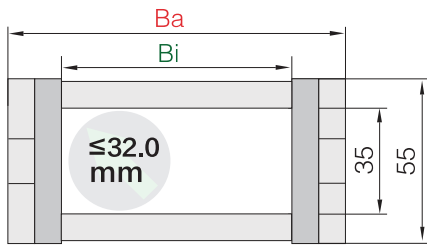

Inner [mm]	25
Height Pitch [mm/link]	67
Number /m	15
= [mm]	1005
Chain Length	$L_k = \frac{S}{2} + K$

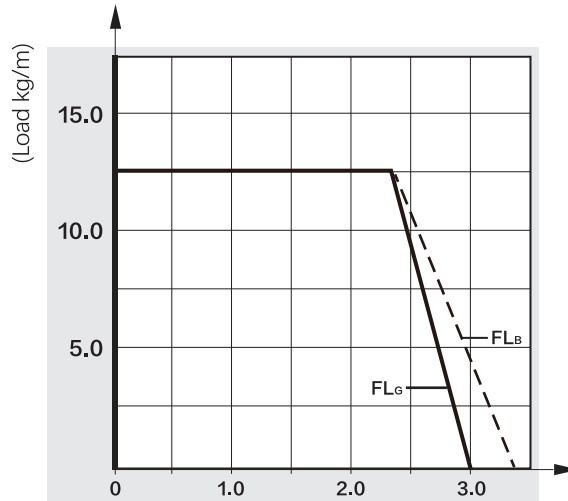

Overhead Operation FL_G/FL_B [m] Travel Distance S [m]

FL_G =Straight Overhead FL_B =Safe Sagging Overhead

Overhead Application | Short Travel

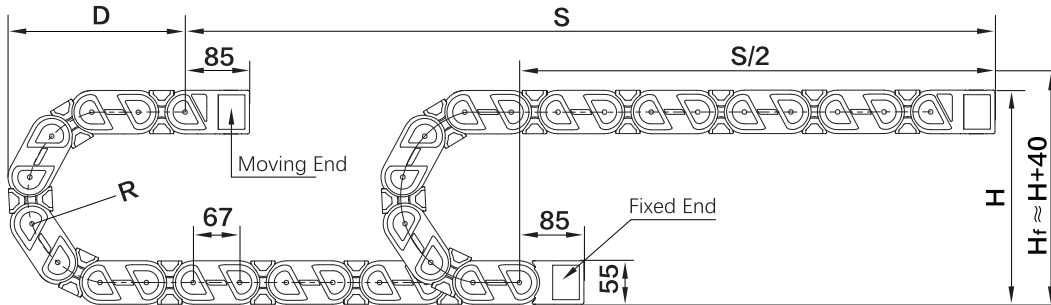

	R	075	100	125	150	175	200	250	300
H		205	255	305	355	405	455	555	655
D		210	235	260	285	310	335	385	435
K		370	450	530	605	685	765	920	1080

Actual Installation Height: $HF \approx H+40mm$

Sliding Application | Long Travels : $L_k = S/2 + K_1 + \Delta M$

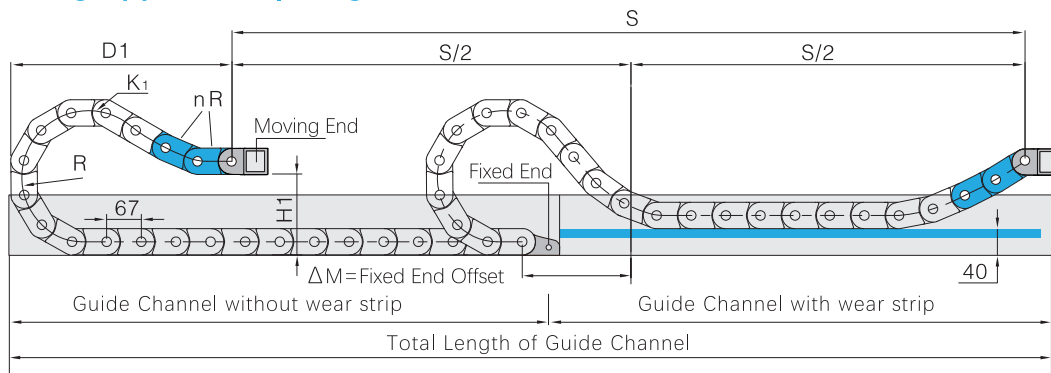

	R	075	100	125	150	175	200	250	300
H ₁		150	165	165	165	165	165	165	165
D ₁		203	230	470	575	725	780	1015	1145
K ₁		365	445	800	1000	1130	1335	1670	1940
ΔC		--	--	235	305	445	465	645	735
nR		--	--	2	2	2	3	3	4

Full Black | H Series | Installation Dimensions

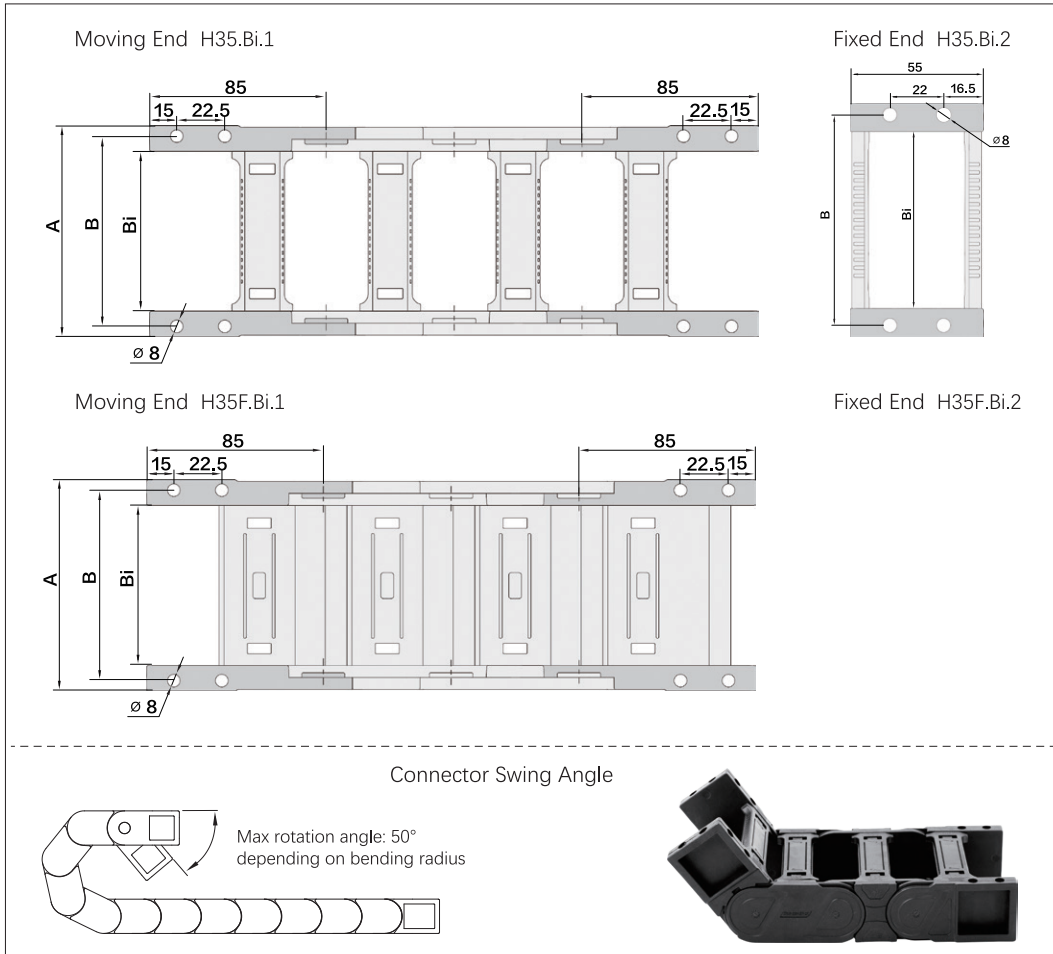

Product Code Complete Set	A [mm]	B [mm]	Bi [mm]
H. 035Q. 050. 12	76	63. 5	50
H. 035Q. 060. 12	86	73. 5	60
H. 035Q. 065. 12	91	78. 5	65
H. 035Q. 075. 12	101	88. 5	75
H. 035Q. 100. 12	126	113. 5	100
H. 035Q. 115. 12	141	128. 5	115
H. 035Q. 125. 12	151	138. 5	125
H. 035Q. 150. 12	176	163. 5	150
H. 035Q. 175. 12	201	188. 5	175
H. 035Q. 200. 12	226	213. 5	200
H. 035Q. 250. 12	276	263. 5	250

Product Code Complete Set	A [mm]	B [mm]	Bi [mm]
H. 035F. 050. 12	76	63. 5	50
H. 035F. 060. 12	86	73. 5	60
H. 035F. 065. 12	91	78. 5	65
H. 035F. 075. 12	101	88. 5	75
H. 035F. 100. 12	126	113. 5	100
H. 035F. 115. 12	141	128. 5	115
H. 035F. 125. 12	151	138. 5	125
H. 035F. 150. 12	176	163. 5	150

Separation Principle | Vertical Divider Horizontal Divider

Note:

Minimum distance D_{min} between vertical divider and side plate inner wall = 11mm. Standard configuration: one set of dividers per two links.

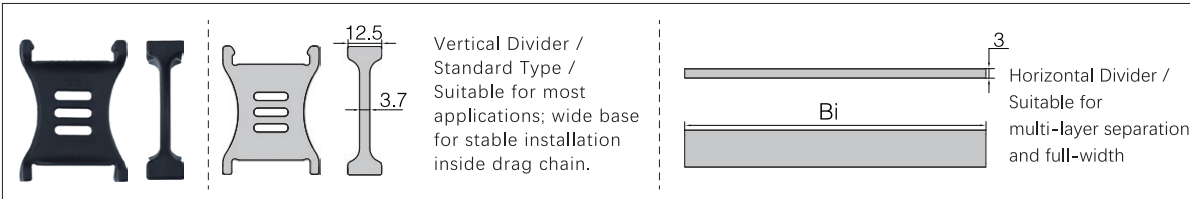
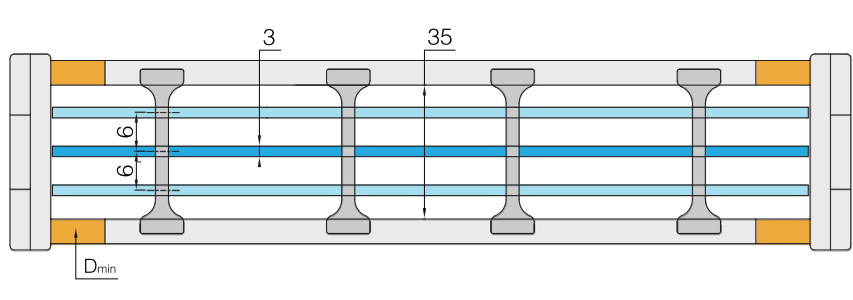

Ordering Example

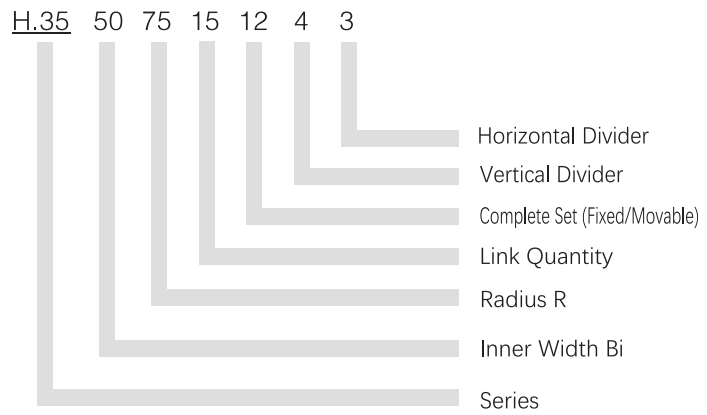

Full Black | H Series | Product Range

Tongue-and-groove structure High stability



Drag Chain | H Series | Bridge type, upper & lower cover openable

Product Code Drag Chain	Bi [mm]	Ba [mm]	R [mm]	Weight [kg/m]
H.45Q.50.R	50	82	100 125 150 175 200 250 300 350	≈ 1.80
H.45Q.60.R	60	92	100 125 150 175 200 250 300 350	≈ 1.87
H.45Q.65.R	65	97	100 125 150 175 200 250 300 350	≈ 1.80
H.45Q.75.R	75	107	100 125 150 175 200 250 300 350	≈ 1.95
H.45Q.100.R	100	132	100 125 150 175 200 250 300 350	≈ 2.08
H.45Q.115.R	115	147	100 125 150 175 200 250 300 350	≈ 2.17
H.45Q.125.R	125	157	100 125 150 175 200 250 300 350	≈ 2.24
H.45Q.150.R	150	182	100 125 150 175 200 250 300 350	≈ 2.36
H.45Q.175.R	175	207	100 125 150 175 200 250 300 350	≈ 2.55
H.45Q.200.R	200	232	100 125 150 175 200 250 300 350	≈ 2.75
H.45Q.250.R	250	282	100 125 150 175 200 250 300 350	≈ 3.20

Complete the model number according to the required bending radius (R), Example: H.45.50Q.R.100

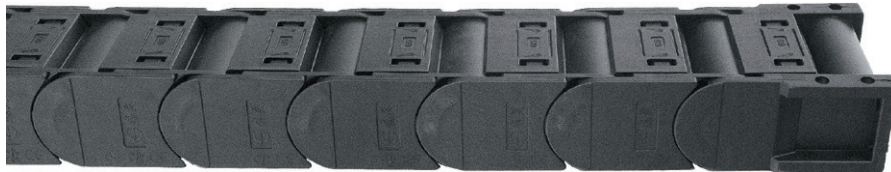

Drag Chain | H Series | Fully enclosed, upper & lower cover openable

Product Code Drag Chain	Bi [mm]	Ba [mm]	R [mm]	Weight [kg/m]
H.45F.60.R	60	92	100 125 150 175 200 250 300 350	≈ 2.17
H.45F.75.R	75	107	100 125 150 175 200 250 300 350	≈ 2.28
H.45F.100.R	100	132	100 125 150 175 200 250 300 350	≈ 2.59
H.45F.125.R	125	157	100 125 150 175 200 250 300 350	≈ 2.74
H.45F.150.R	150	182	100 125 150 175 200 250 300 350	≈ 3.15

Complete the model number according to the required bending radius (R), Example: H.45.60F.R.100

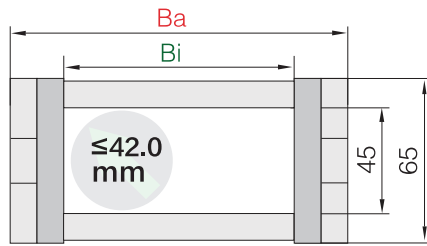

Inner [mm]	45
Height Pitch [mm/link]	80
Number /m	13
= [mm]	1040
Chain Length	$L_k = S/2 + K$

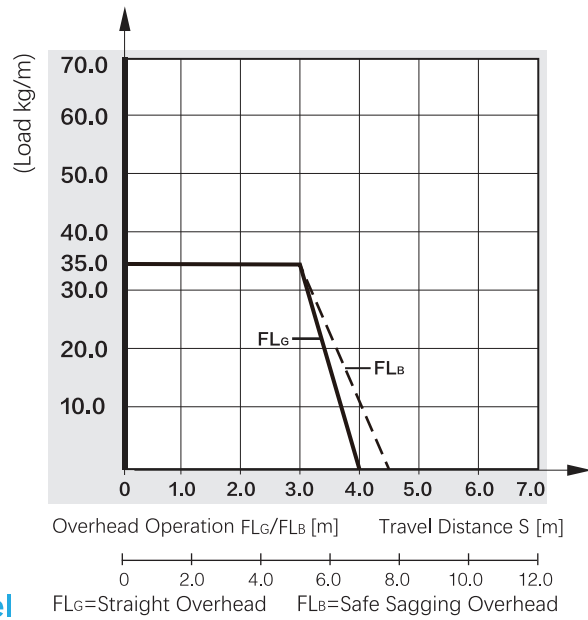

Overhead Application | Short Travel

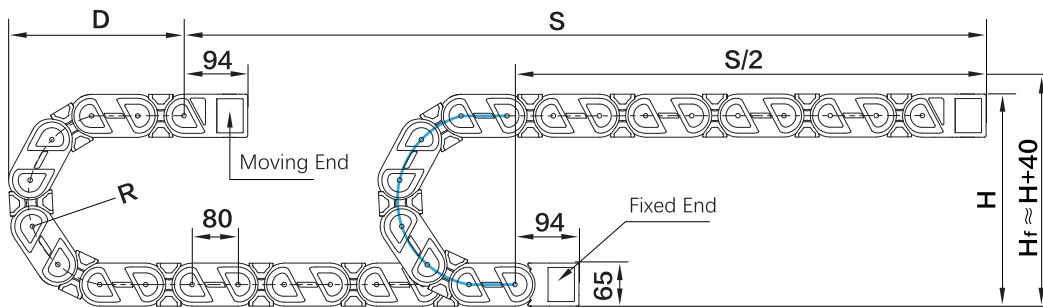

R	100	125	150	175	200	250	300	350
H	265	315	365	415	465	565	665	765
D	260	285	310	335	360	410	460	510
K	475	553	631	710	790	977	1105	1260

Actual Installation Height: $H_f \approx H+40\text{mm}$

Sliding Application | Long Travels : $L_k = S/2 + K_1 + \Delta M$

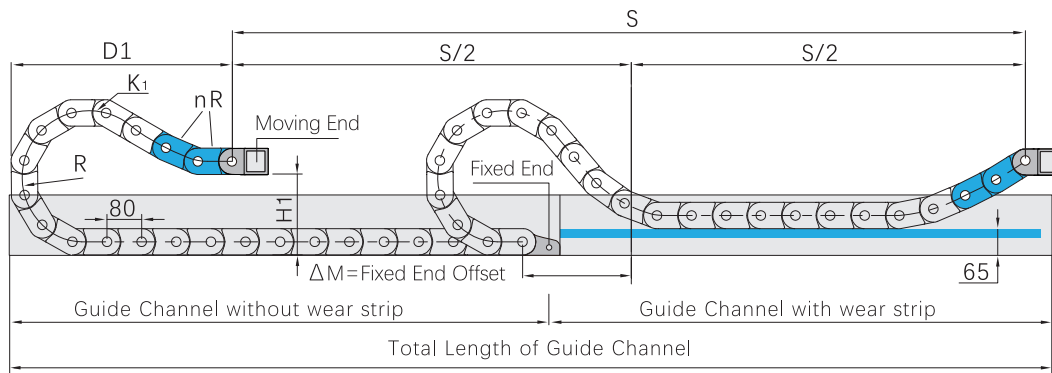

R	100	125	150	175	200	250	300	350
H1	200	195	195	195	195	195	195	195
D1	260	285	505	635	780	1000	1180	1470
K1	475	553	826	1000	1200	1580	1830	2230
ΔC	--	--	195	300	410	600	720	970
nR	--	--	2	2	3	3	4	4

Full Black | H Series | Installation Dimensions

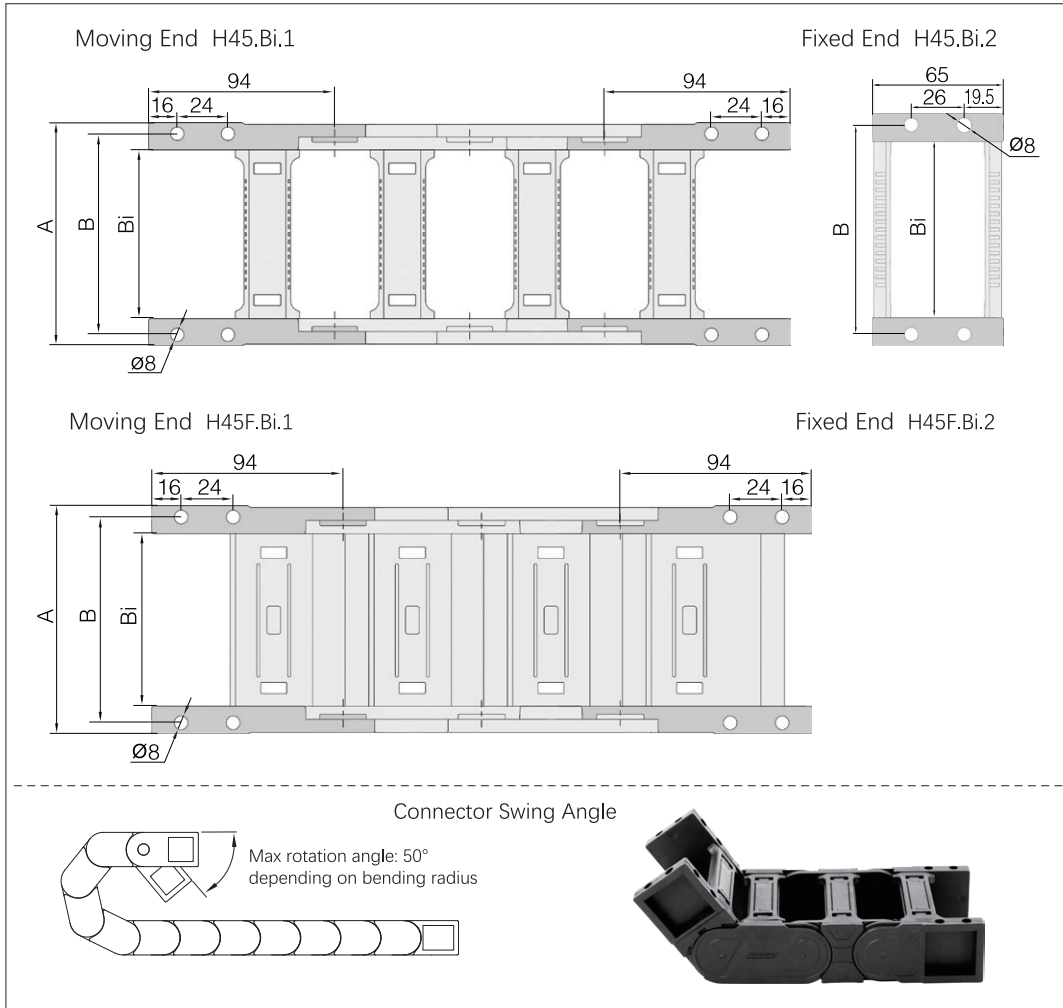

Product Code Complete Set	A [mm]	B [mm]	Bi [mm]
H.045Q.050.12	82	67	50
H.045Q.060.12	92	77	60
H.045Q.065.12	97	82	65
H.045Q.075.12	107	92	75
H.045Q.100.12	132	117	100
H.045Q.115.12	147	132	115
H.045Q.125.12	157	142	125
H.045Q.150.12	182	167	150
H.045Q.175.12	207	192	175
H.045Q.200.12	232	217	200
H.045Q.250.12	282	267	250

Product Code Complete Set	A [mm]	B [mm]	Bi [mm]
H.045F.060.12	92	77	60
H.045F.075.12	107	92	75
H.045F.100.12	132	117	100
H.045F.125.12	157	142	125
H.045F.150.12	182	167	150

Separation Principle | Vertical Divider Horizontal Divider

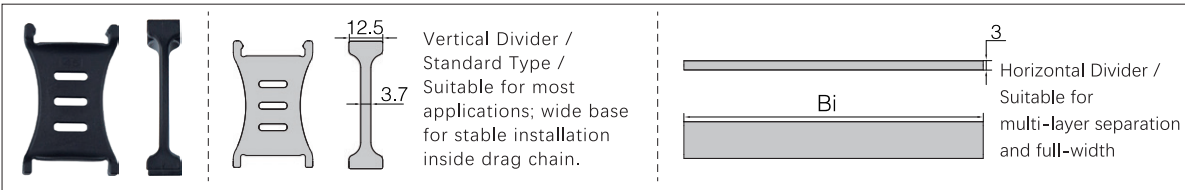
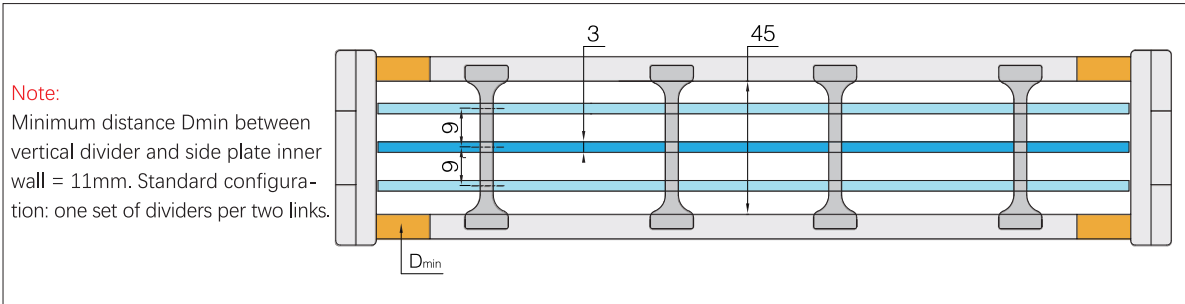

Ordering Example

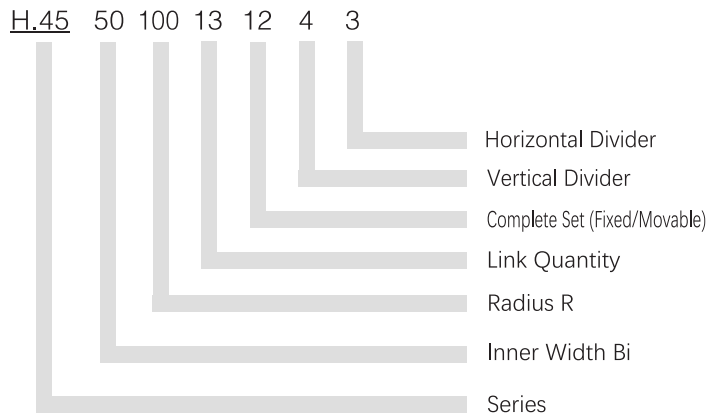
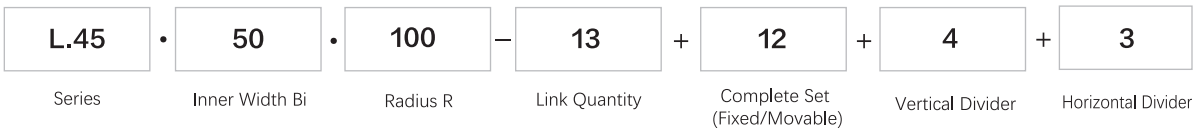

Full Black | H Series | Product Range

Tongue-and-groove structure High stability



Drag Chain | H Series | Bridge type, upper & lower cover openable

Product Code Drag Chain	Bi [mm]	Ba [mm]	R [mm]	Weight [kg/m]
H.55Q.50.R	50	82	125 150 175 200 250 300	≈ 2.69
H.55Q.60.R	60	92	125 150 175 200 250 300	≈ 2.77
H.55Q.65.R	65	97	125 150 175 200 250 300	≈ 2.70
H.55Q.75.R	75	107	125 150 175 200 250 300	≈ 2.85
H.55Q.100.R	100	132	125 150 175 200 250 300	≈ 2.98
H.55Q.115.R	115	147	125 150 175 200 250 300	≈ 3.07
H.55Q.125.R	125	157	125 150 175 200 250 300	≈ 3.14
H.55Q.150.R	150	182	125 150 175 200 250 300	≈ 3.26
H.55Q.175.R	175	207	125 150 175 200 250 300	≈ 3.45
H.55Q.200.R	200	232	125 150 175 200 250 300	≈ 3.65
H.55Q.250.R	250	282	125 150 175 200 250 300	--

Complete the model number according to the required bending radius (R), Example: H.55Q.50.R.125

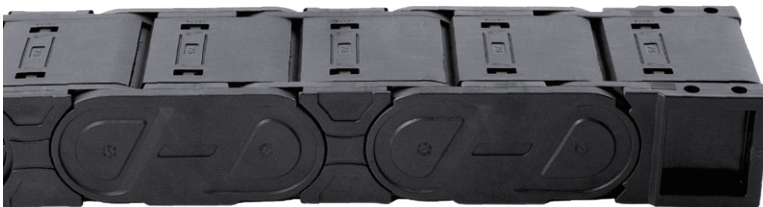

Drag Chain | H Series | Fully enclosed, upper & lower cover openable

Product Code Drag Chain	Bi [mm]	Ba [mm]	R [mm]	Weight [kg/m]
H.55F.60.R	50	92	125 150 175 200 250 300	≈ 2.90
H.55F.75.R	60	107	125 150 175 200 250 300	≈ 3.09
H.55F.100.R	65	132	125 150 175 200 250 300	≈ 3.33
H.55F.125.R	75	157	125 150 175 200 250 300	≈ 3.69
H.55F.150.R	100	182	125 150 175 200 250 300	≈ 4.00

Complete the model number according to the required bending radius (R), Example: H.55F.60.R.125

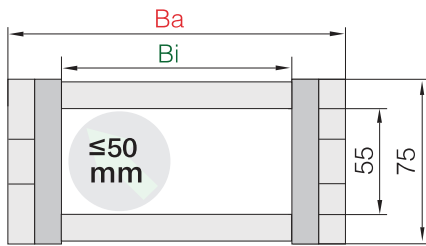

Inner [mm]	55
Height Pitch [mm/link]	80
Number /m	13
= [mm]	1040
Chain Length	$L_k = \frac{S}{2} + K$

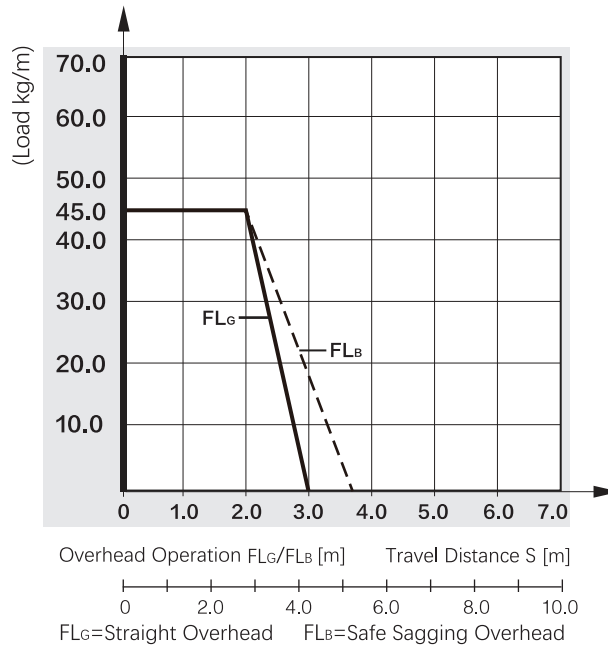

Overhead Application | Short Travel

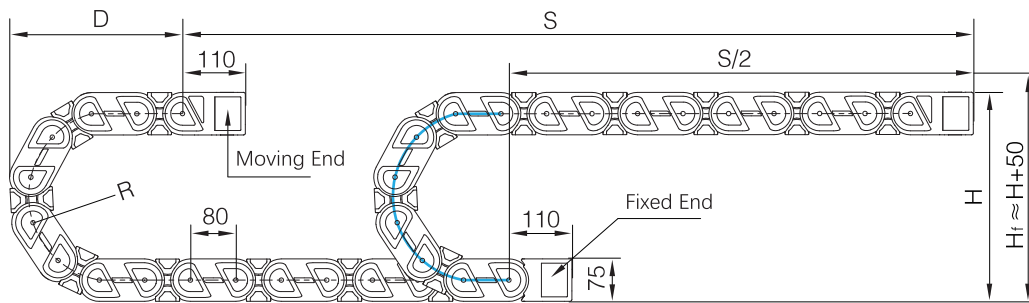

R	125	150	175	200	250	300
H	325	375	425	475	575	675
D	285	310	335	360	410	460
K	553	631	710	790	977	1105

Actual Installation Height: $H_f \approx H+50\text{mm}$

Sliding Application | Long Travels : $L_k = S/2 + K_1 + \Delta M$

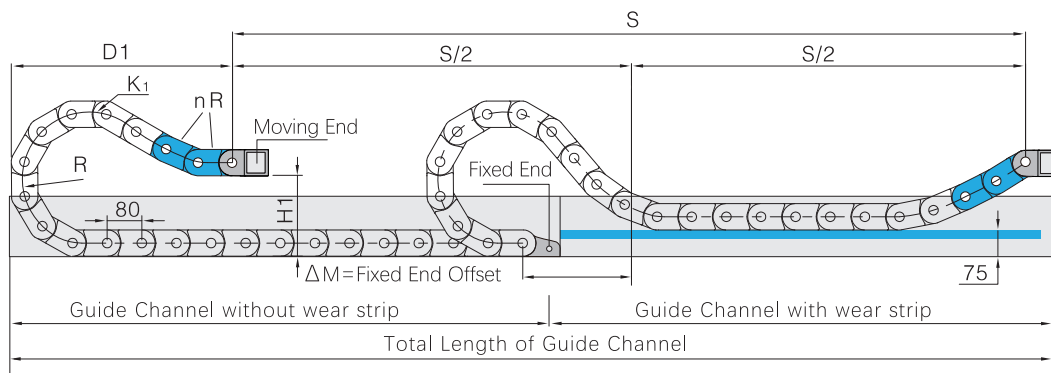

R	125	150	175	200	250	300
H1	225	225	225	225	225	225
D1	285	505	635	780	1000	1180
K1	553	826	1000	1200	1580	1830
ΔC	--	195	300	410	600	720
nR	--	2	2	3	3	4

Full Black | H Series | Installation Dimensions

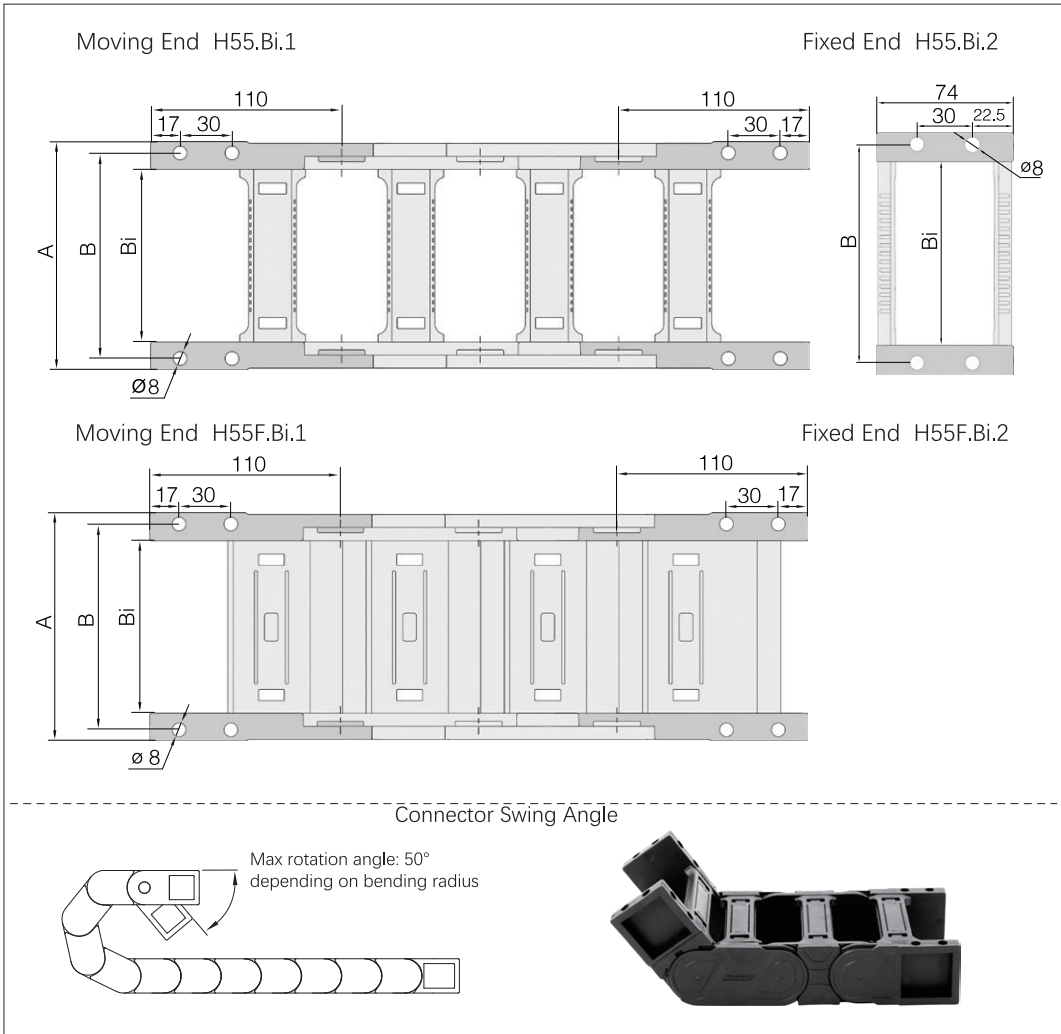

Product Code Complete Set	A [mm]	B [mm]	Bi [mm]
H.055Q.050.12	82	69	50
H.055Q.060.12	92	79	60
H.055Q.065.12	97	84	65
H.055Q.075.12	107	94	75
H.055Q.100.12	132	119	100
H.055Q.115.12	147	134	115
H.055Q.125.12	157	144	125
H.055Q.150.12	182	169	150
H.055Q.175.12	207	194	175
H.055Q.200.12	232	219	200
H.055Q.250.12	282	269	250

Product Code Complete Set	A [mm]	B [mm]	Bi [mm]
H.055F.060.12	92	79	60
H.055F.075.12	107	94	75
H.055F.100.12	132	119	100
H.055F.125.12	157	144	125
H.055F.150.12	182	169	150

Separation Principle | Vertical Divider Horizontal Divider

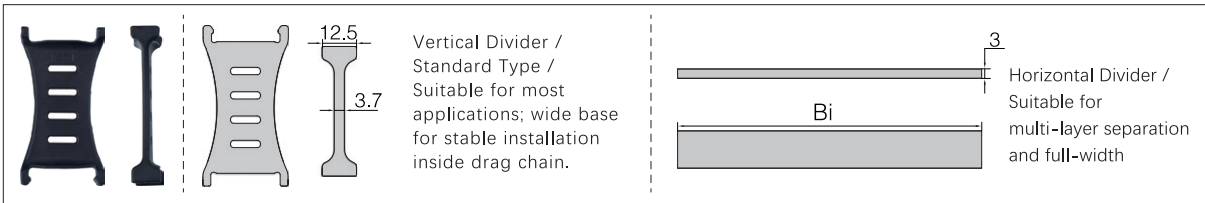
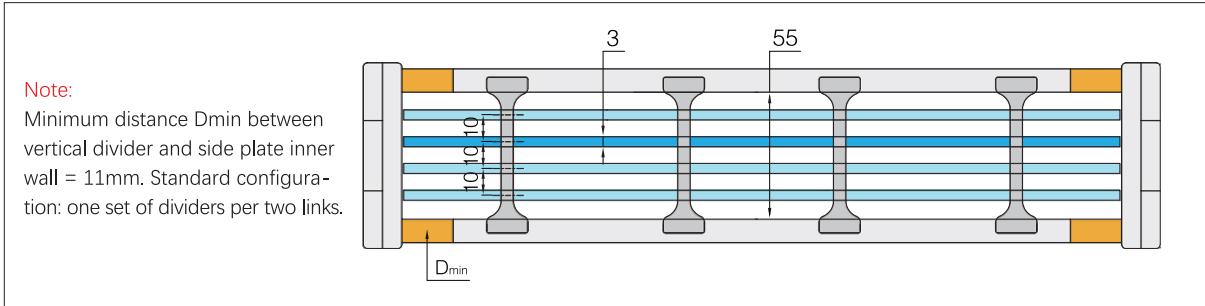

Ordering Example

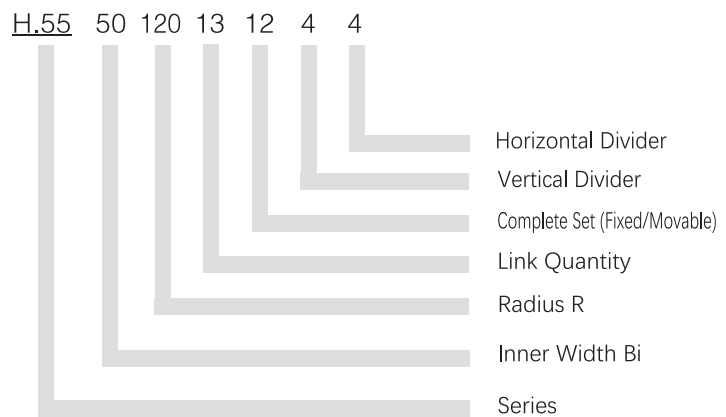
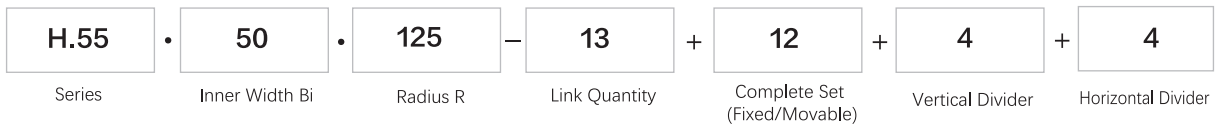

Full Black 62 Series

Full Black | H Series | Product Range

Tongue-and-groove structure High stability



Drag Chain | H Series | Bridge type, upper & lower cover openable

Product Code Drag Chain	Bi [mm]	Ba [mm]	R [mm]	Weight [kg/m]
H.62Q.60.R	60	100	150 175 200 225 250 300 400 500	≈ 3.97
H.62Q.95.R	95	135	150 175 200 225 250 300 400 500	≈ 4.25
H.62Q.125.R	125	165	150 175 200 225 250 300 400 500	≈ 4.44
H.62Q.150.R	150	190	150 175 200 225 250 300 400 500	≈ 4.59
H.62Q.175.R	175	215	150 175 200 225 250 300 400 500	≈ 4.70
H.62Q.200.R	200	240	150 175 200 225 250 300 400 500	≈ 4.82
H.62Q.225.R	225	265	150 175 200 225 250 300 400 500	≈ 5.14
H.62Q.250.R	250	290	150 175 200 225 250 300 400 500	≈ 5.42
H.62Q.300.R	300	340	150 175 200 225 250 300 400 500	≈ 5.74

Complete the model number according to the required bending radius (R), Example: H.62Q.60.R.150



Drag Chain | H Series | Fully enclosed, upper & lower cover openable

Product Code Drag Chain	Bi [mm]	Ba [mm]	R [mm]	Weight [kg/m]
H.62F.100.R	100	140	150 175 200 225 250 300 400 500	≈ 4.73
H.62F.150.R	150	190	150 175 200 225 250 300 400 500	≈ 5.25
H.62F.200.R	200	240	150 175 200 225 250 300 400 500	≈ 5.80

Complete the model number according to the required bending radius (R), Example: H.62F.100.R.150

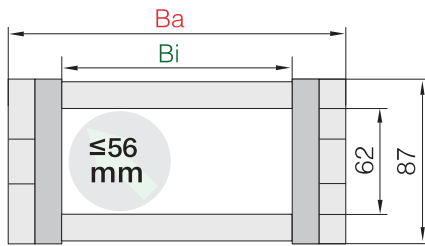

Inner [mm]	62
Height Pitch [mm/link]	90
Number /m	12
=[mm]	1080
Chain Length	$L_k = S/2 + K$

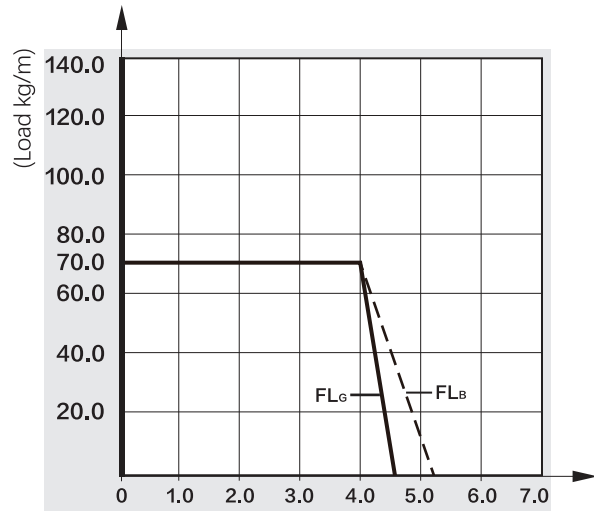

Overhead Operation FL_G/FL_B [m] Travel Distance S [m]
 FL_G =Straight Overhead FL_B =Safe Sagging Overhead

Overhead Application | Short Travel

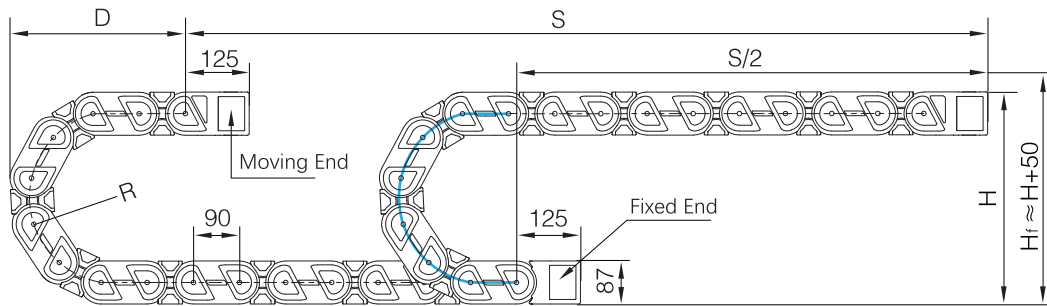

R	150	175	200	225	250	300	400	500
H	387	437	487	537	587	687	887	1087
D	350	375	400	425	450	500	600	700
K	670	750	830	910	985	1145	1455	1770

Actual Installation Height: $H_f \approx H + 50\text{mm}$

Sliding Application | Long Travels : $L_k = S/2 + K_1 + \Delta M$

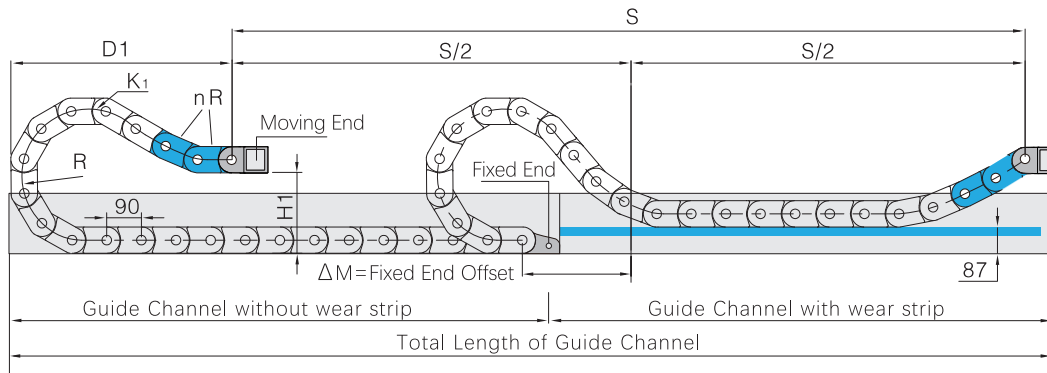

R	150	175	200	225	250	300	400	500
H_f	300	310	310	310	310	310	310	310
D_1	500	600	760	850	960	1160	1560	1960
K_1	860	1060	1300	1460	1650	1950	2600	3320
ΔC	175	290	375	450	525	700	975	1280
nR	--	2	2	2	3	3	4	4

Full Black | H Series | Installation Dimensions

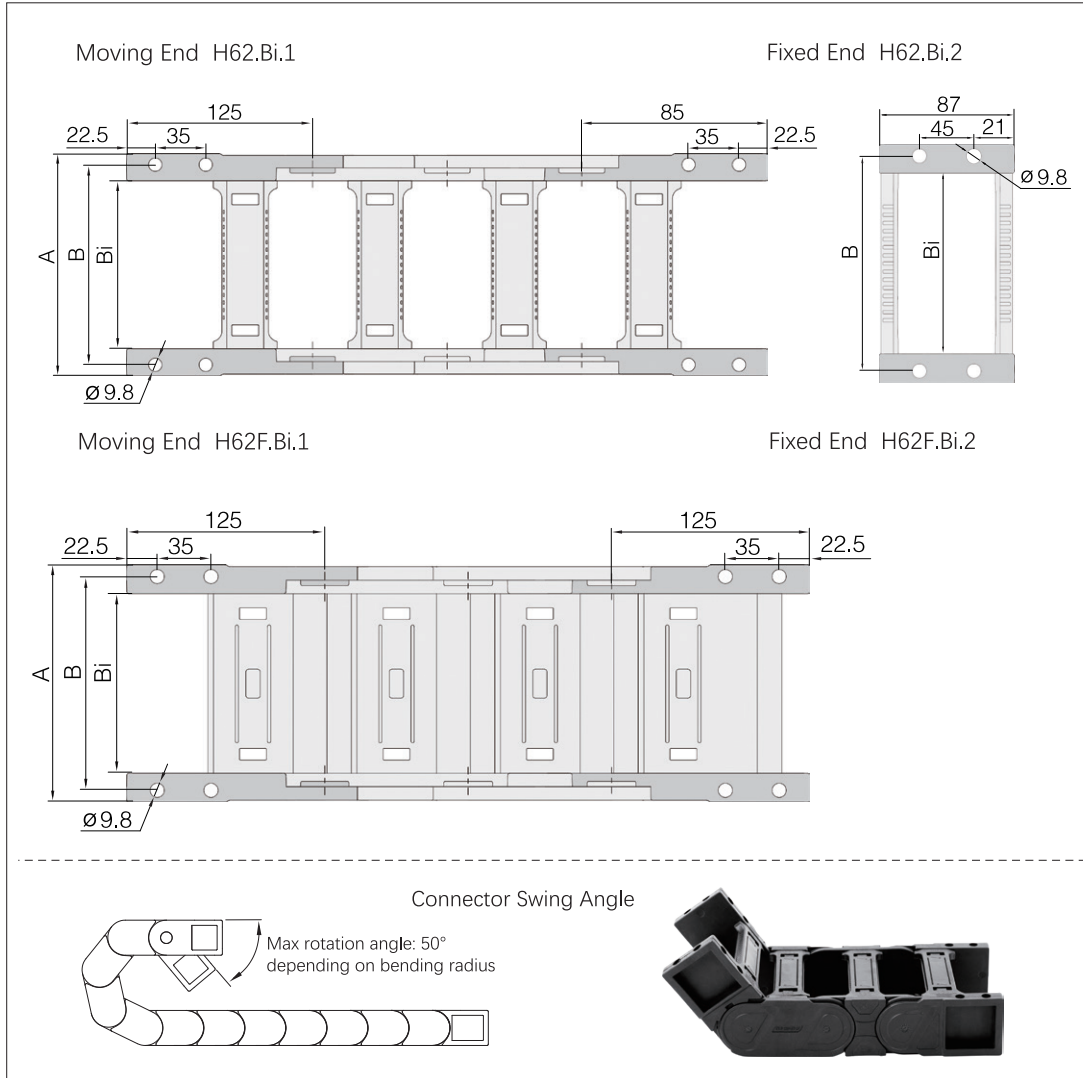

Product Code Complete Set	A [mm]	B [mm]	Bi [mm]
H.062Q.060.12	100	82	60
H.062Q.095.12	135	117	95
H.062Q.125.12	165	147	125
H.062Q.150.12	190	172	150
H.062Q.175.12	215	197	175
H.062Q.200.12	240	222	200
H.062Q.225.12	265	247	225
H.062Q.250.12	290	272	250
H.062Q.300.12	340	322	300

Product Code Complete Set	A [mm]	B [mm]	Bi [mm]
H.062F.100.12	140	122	100
H.062F.150.12	190	172	150
H.062F.200.12	240	222	200

Separation Principle | Vertical Divider Horizontal Divider

Note:

Minimum distance D_{min} between vertical divider and side plate inner wall = 36mm. Standard configuration: one set of dividers per two links.

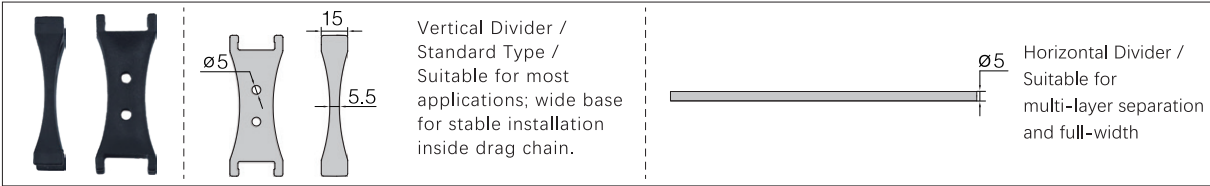
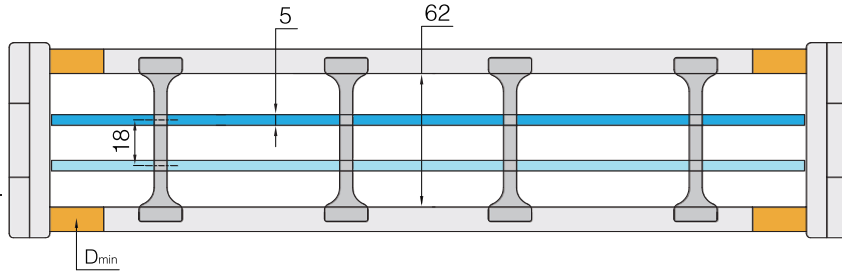

Ordering Example

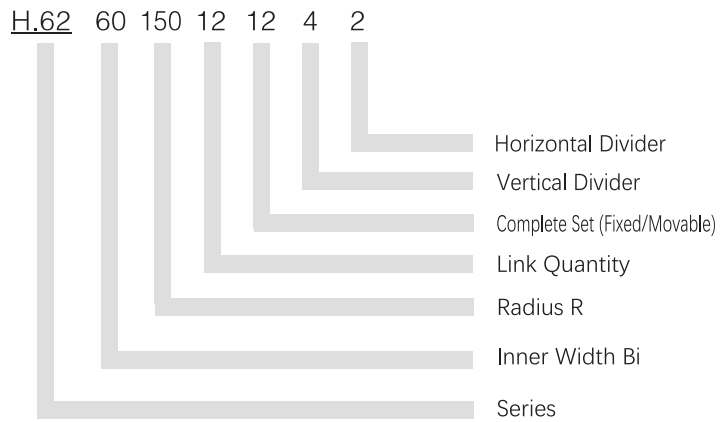
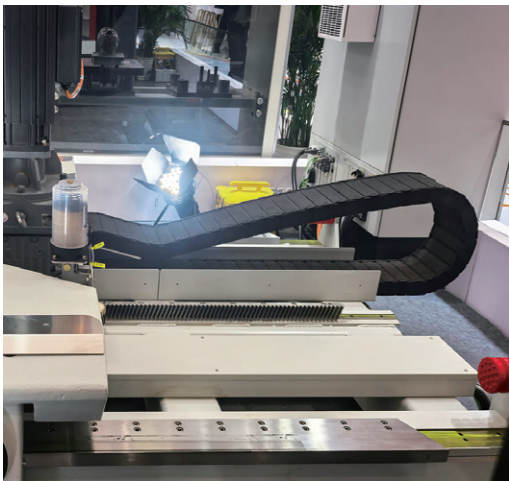

Full Black | H Series | Product Range

Tongue-and-groove structure High stability



Drag Chain | H Series | Bridge type, upper & lower cover openable

Product Code Drag Chain	Bi [mm]	Ba [mm]	R [mm]	Weight [kg/m]
H.80Q.60.R	60	109	150 175 200 225 250 300 400 500	≈ 4.67
H.80Q.95.R	95	144	150 175 200 225 250 300 400 500	≈ 4.92
H.80Q.125.R	125	174	150 175 200 225 250 300 400 500	≈ 5.01
H.80Q.150.R	150	199	150 175 200 225 250 300 400 500	≈ 5.14
H.80Q.175.R	175	224	150 175 200 225 250 300 400 500	≈ 5.34
H.80Q.200.R	200	249	150 175 200 225 250 300 400 500	≈ 5.44
H.80Q.225.R	225	274	150 175 200 225 250 300 400 500	≈ 5.73
H.80Q.250.R	250	299	150 175 200 225 250 300 400 500	≈ 5.99
H.80Q.300.R	300	349	150 175 200 225 250 300 400 500	≈ 6.26

Complete the model number according to the required bending radius (R), Example: H.80Q.60.R.150



Drag Chain | H Series | Fully enclosed, upper & lower cover openable

Product Code Drag Chain	Bi [mm]	Ba [mm]	R [mm]	Weight [kg/m]
H.80F.150.R	150	199	150 175 200 225 250 300 400 500	≈ 5.58
H.80F.175.R	175	224	150 175 200 225 250 300 400 500	≈ 5.78
H.80F.300.R	300	349	150 175 200 225 250 300 400 500	≈ 9.98

Complete the model number according to the required bending radius (R), Example: H.80F.150.R.150

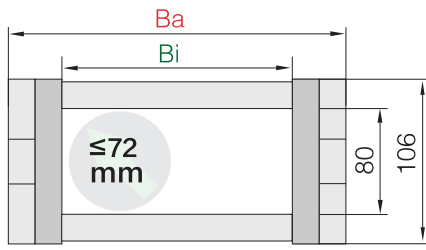

Inner [mm]	80
Height Pitch [mm/link]	109
Number /m =[mm]	9 981
Chain Length	$L_k = S/2 + K$

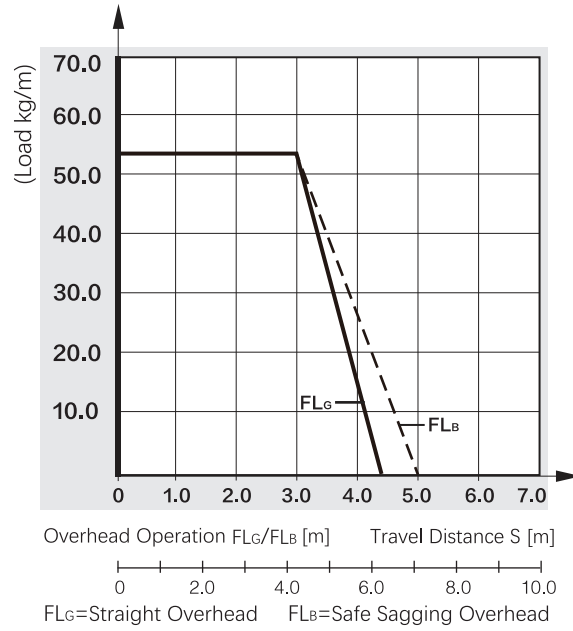

Overhead Application | Short Travel

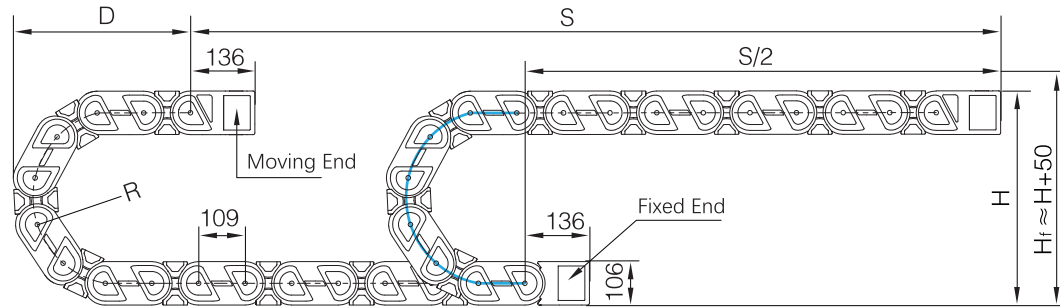

R	150	200	225	250	300	350	400	500	600
H	406	506	556	606	706	806	906	1106	1306
D	370	420	445	470	520	570	620	720	820
K	695	850	930	1105	1162	1320	1476	1790	2100

Actual Installation Height: HF ≈ H+50mm

Sliding Application | Long Travels : $L_k = S/2 + K_1 + \Delta M$

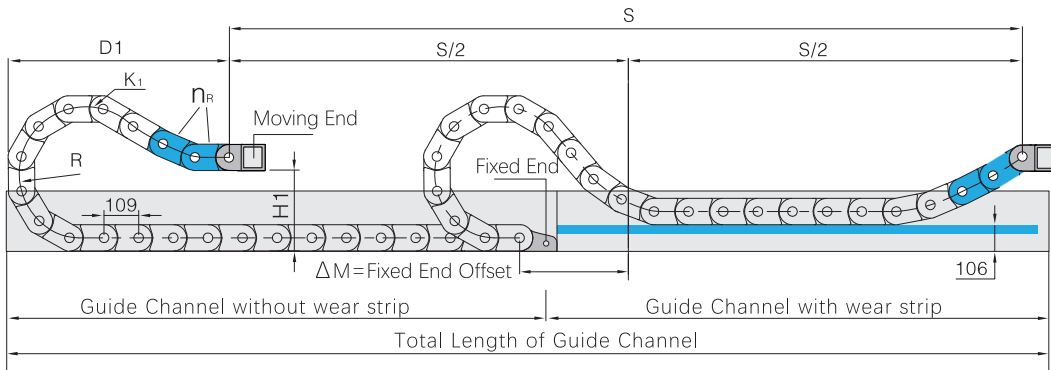

R	150	200	225	250	300	350	400	500	600
H1	300	320	320	320	320	320	320	320	320
D1	555	805	900	1000	1200	1450	1600	2110	2500
K1	895	1335	1500	1670	2000	2330	2660	3450	4100
ΔC	190	390	465	540	690	890	990	1390	1690
nR	--	2	2	2	3	3	4	4	4

Full Black | H Series | Installation Dimensions

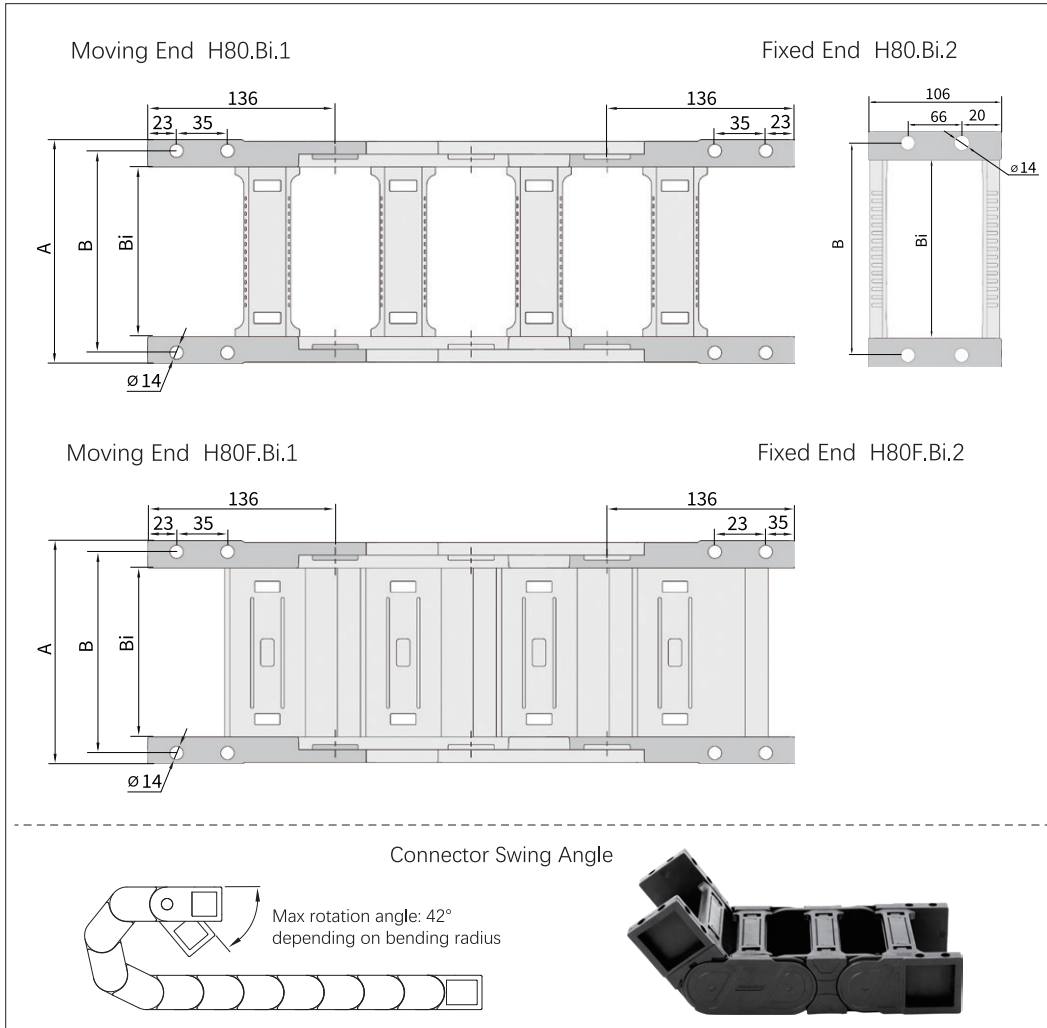

Product Code Complete Set	A [mm]	B [mm]	Bi [mm]
H.080Q.060.12	109	86	60
H.080Q.095.12	144	121	95
H.080Q.125.12	174	151	125
H.080Q.150.12	199	176	150
H.080Q.175.12	224	201	175
H.080Q.200.12	249	226	200
H.080Q.225.12	274	251	225
H.080Q.250.12	299	276	250
H.080Q.300.12	349	326	300

Product Code Complete Set	A [mm]	B [mm]	Bi [mm]
H.080F.150.12	199	176	150
H.080F.175.12	224	201	175
H.080F.300.12	349	326	300

Separation Principle | Vertical Divider Horizontal Divider

Note:

Minimum distance D_{min} between vertical divider and side plate inner wall = 36mm. Standard configuration: one set of dividers per two links.

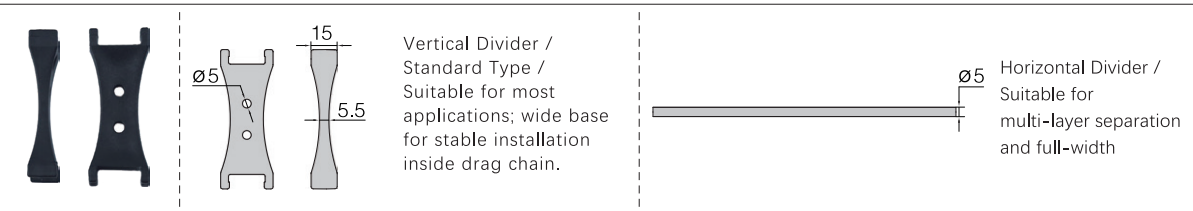
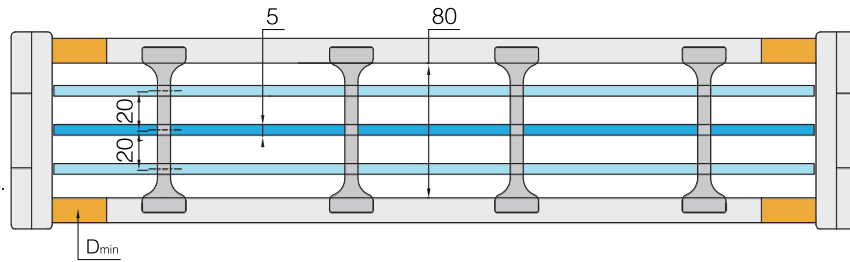

Ordering Example

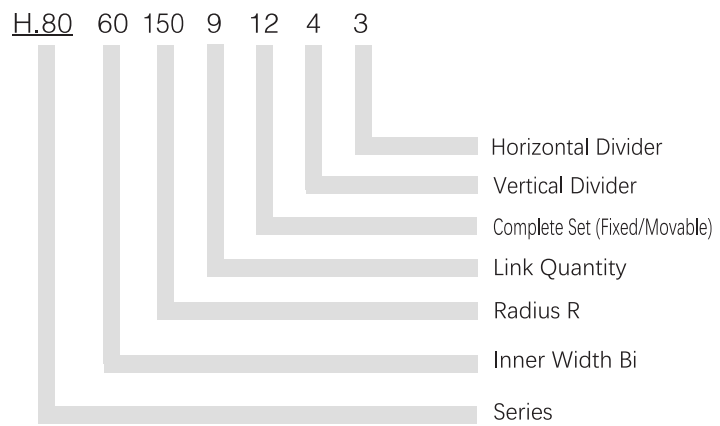
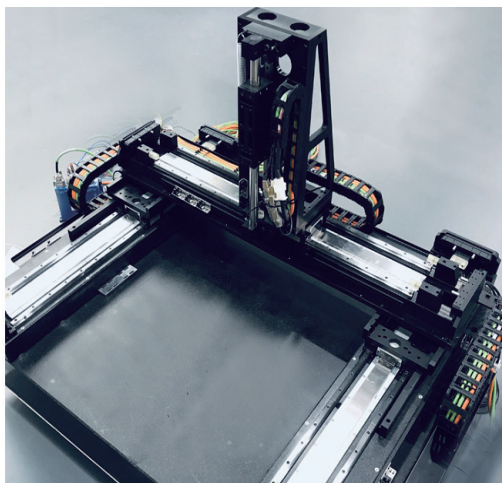
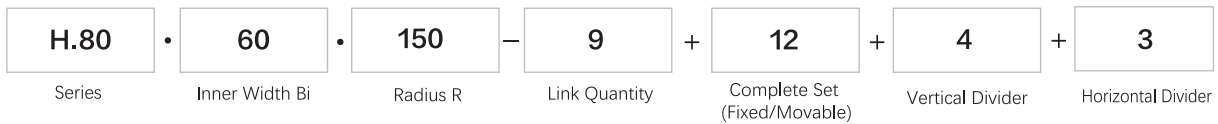

Yellow Buckle Economy | K Series | Product Range

Wide applicability Cost-effective



Drag Chain | K Series | Bridge type, upper & lower cover openable

Product Code Drag Chain	Bi [mm]	Ba [mm]	R [mm]	Weight [kg/m]
K.20Q.25.R	25	48	055 075 100 125	≈0.81
K.20Q.38.R	38	61	055 075 100 125	≈0.88
K.20Q.50.R	50	73	055 075 100 125	≈0.96
K.20Q.57.R	57	80	055 075 100 125	≈0.99
K.20Q.65.R	65	88	055 075 100 125	≈0.99
K.20Q.70.R	70	93	055 075 100 125	≈1.07
K.20Q.75.R	75	98	055 075 100 125	≈1.10
K.20Q.100.R	100	123	055 075 100 125	≈1.12
K.20Q.103.R	103	126	055 075 100 125	≈1.13

Complete the model number according to the required bending radius (R), Example: K.20Q.25.R.055



Drag Chain | K Series | Fully enclosed, upper & lower cover openable

Product Code Drag Chain	Bi [mm]	Ba [mm]	R [mm]	Weight [kg/m]
K.20F.25.R	25	48	055 075 100 125	≈0.95
K.20F.38.R	38	61	055 075 100 125	≈1.06
K.20F.50.R	50	73	055 075 100 125	≈1.19
K.20F.57.R	57	80	055 075 100 125	≈1.26
K.20F.75.R	75	98	055 075 100 125	≈1.55

Complete the model number according to the required bending radius (R), Example: K.20F.25.R.055

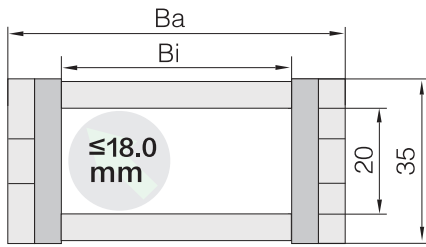

Inner [mm]	20
Height Pitch [mm/link]	47
Number /m	22
= [mm]	1034
Chain Length	$L_k = \frac{S}{2} + K$

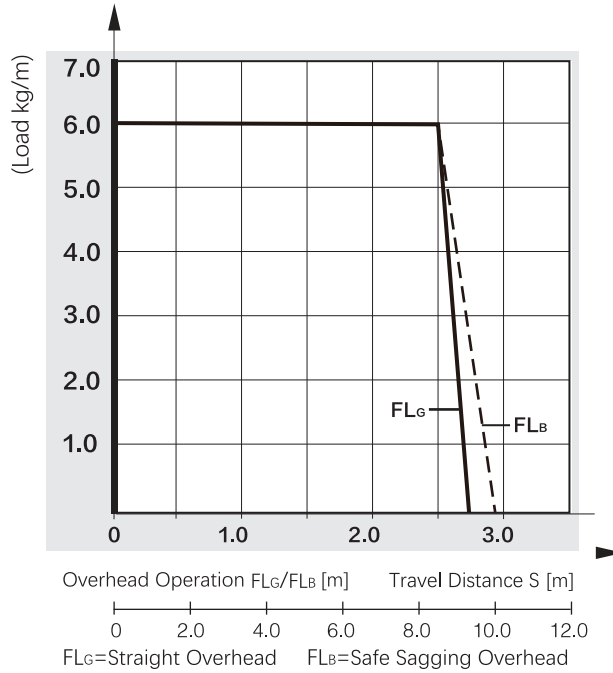

Overhead Application | Short Travel

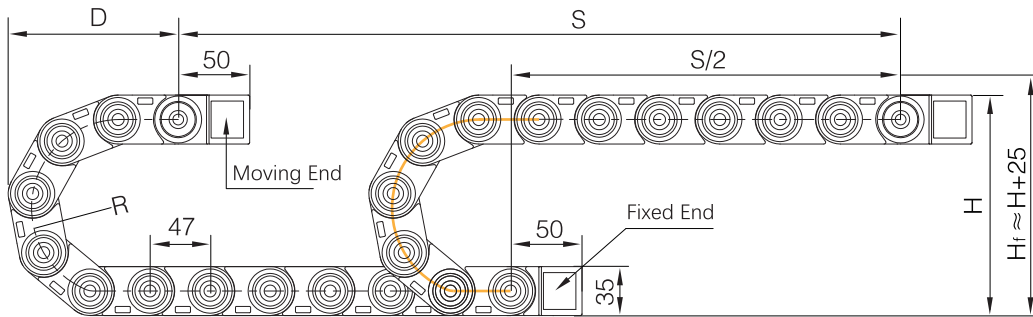

R	055	075	100	125
H	145	185	235	285
D	149	169	194	219
K	267	330	408	487

Actual Installation Height: $HF \approx H + 25\text{mm}$

Sliding Application | Long Travels : $L_k = S/2 + K_1 + \Delta M$

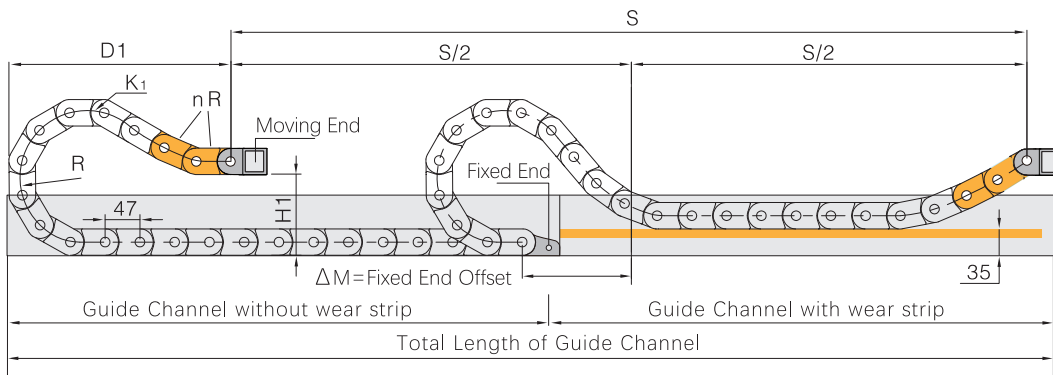

R	055	075	100	125
H1	110	105	105	105
D1	146	260	380	445
K1	265	415	645	736
ΔC	--	115	210	240
nR	--	2	2	3

Yellow Buckle Economy | K Series | Installation Dimensions

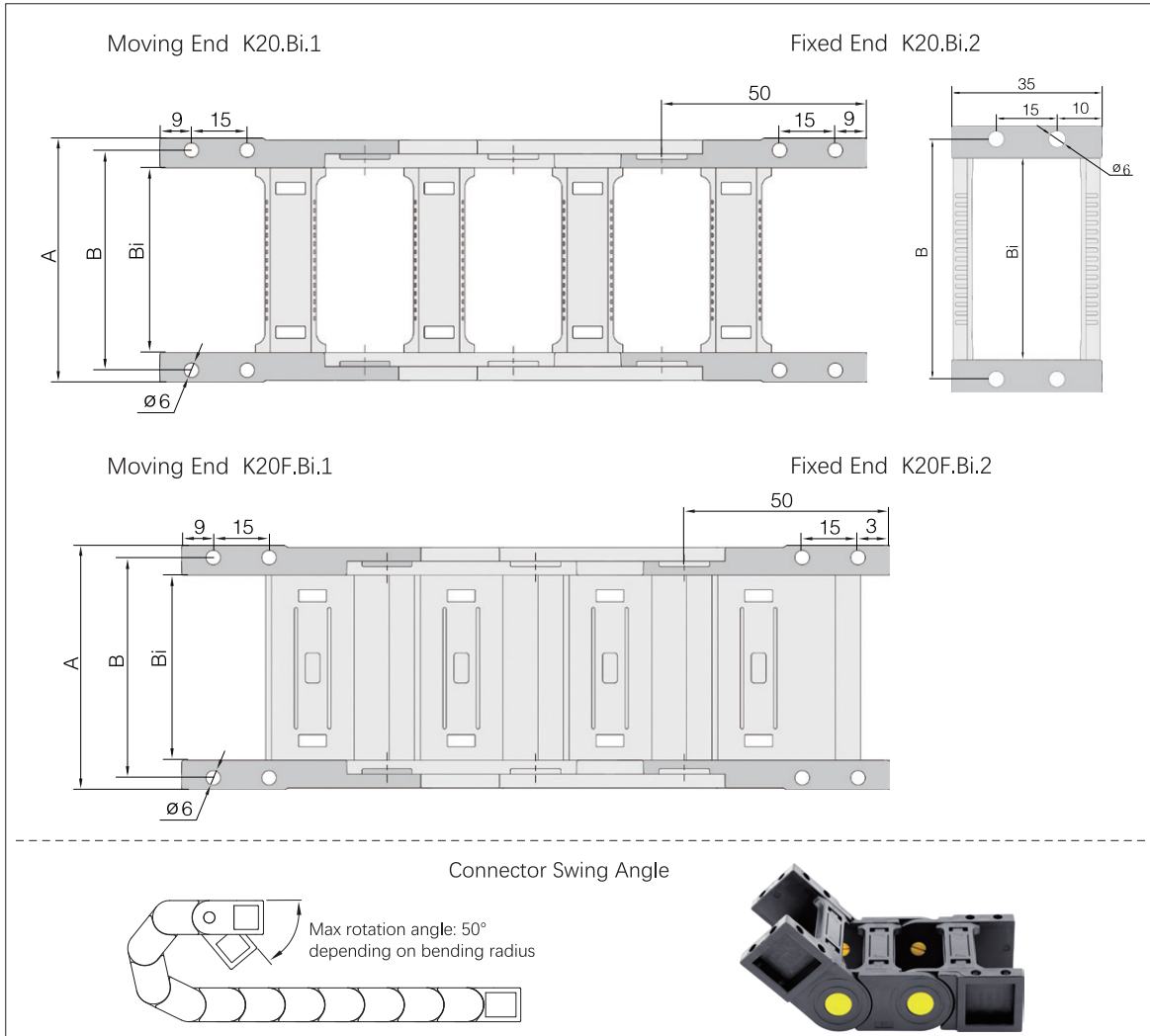

Product Code Complete Set	A [mm]	B [mm]	Bi [mm]
K.020Q.025.12	48	39	25
K.020Q.038.12	61	52	38
K.020Q.050.12	73	64	50
K.020Q.057.12	80	71	57
K.020Q.065.12	88	79	65
K.020Q.070.12	93	84	70
K.020Q.075.12	108	89	75
K.020Q.100.12	123	114	100
K.020Q.103.12	126	117	103

Product Code Complete Set	A [mm]	B [mm]	Bi [mm]
K.020F.025.12	48	39	25
K.020F.038.12	61	52	38
K.020F.050.12	73	64	50
K.020F.057.12	80	71	57
K.020F.075.12	108	89	75

 Ordering Example

K.20	•	25	•	055	—	22	+	12
Series		Inner Width Bi		Radius R		Link Quantity		Complete Set (Fixed/Movable)

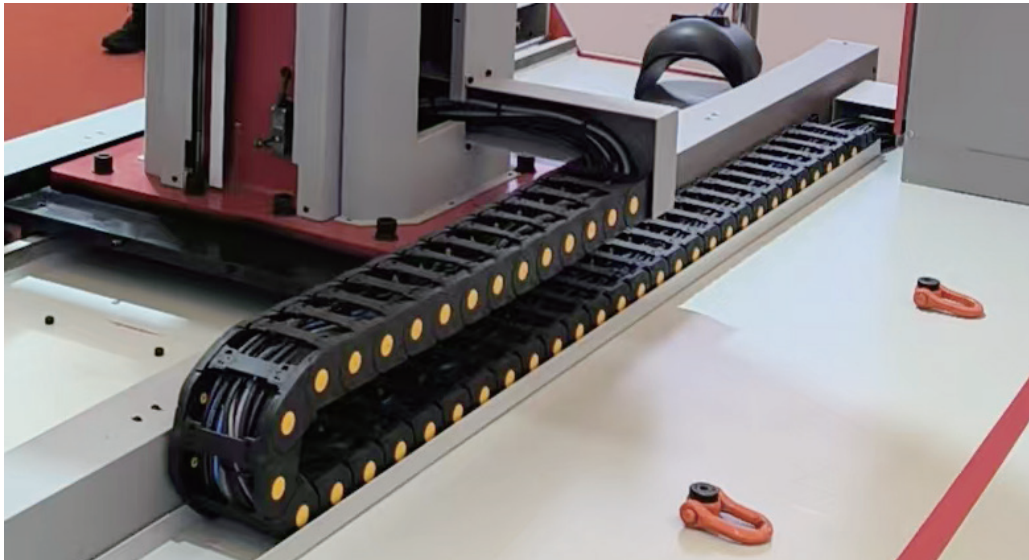

Yellow Buckle Economy 25 Series

Yellow Buckle Economy | K Series | Product Range

Wide applicability Cost-effective

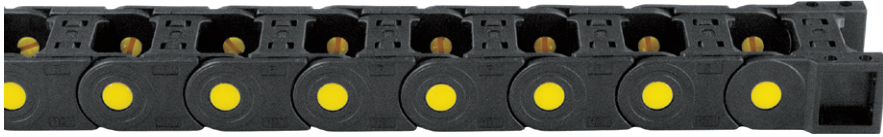

Drag Chain | K Series | Bridge type, upper & lower cover openable

Product Code Drag Chain	Bi [mm]	Ba [mm]	R [mm]	Weight [kg/m]
K.25Q.25.R	25	49	055 075 100 125 150	≈ 0.88
K.25Q.38.R	38	63	055 075 100 125 150	≈ 0.95
K.25Q.50.R	50	74	055 075 100 125 150	≈ 1.06
K.25Q.57.R	57	81	055 075 100 125 150	≈ 1.07
K.25Q.65.R	65	89	055 075 100 125 150	≈ 1.06
K.25Q.70.R	70	94	055 075 100 125 150	≈ 1.17
K.25Q.75.R	75	99	055 075 100 125 150	≈ 1.23
K.25Q.100.R	100	124	055 075 100 125 150	≈ 1.19
K.25Q.103.R	103	127	055 075 100 125 150	≈ 1.25

Complete the model number according to the required bending radius (R), Example: K.25Q.25.R.055



Drag Chain | K Series | Fully enclosed, upper & lower cover openable

Product Code Drag Chain	Bi [mm]	Ba [mm]	R [mm]	Weight [kg/m]
K.25F.25.R	25	49	055 075 100 125 150	≈ 0.98
K.25F.38.R	38	62	055 075 100 125 150	≈ 1.13
K.25F.50.R	50	74	055 075 100 125 150	≈ 1.23
K.25F.57.R	57	81	055 075 100 125 150	≈ 1.33
K.25F.75.R	75	99	055 075 100 125 150	≈ 1.62

Complete the model number according to the required bending radius (R), Example: K.25F.25.R.055

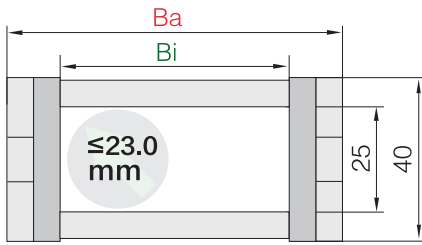

Inner [mm]	25
Height Pitch [mm/link]	47
Number /m	22
= [mm]	1034
Chain Length	$L_k = S/2 + K$

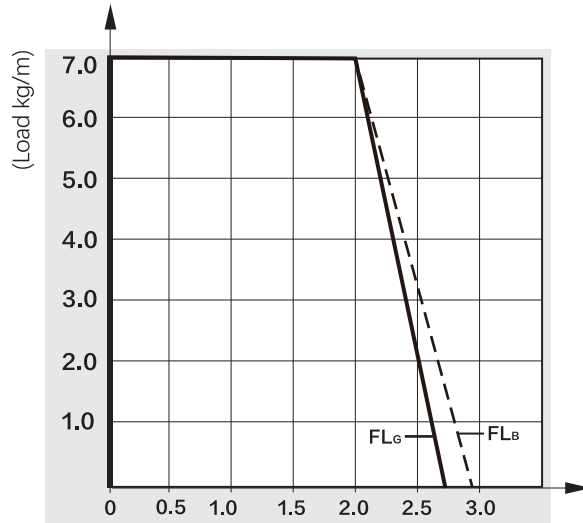

Overhead Operation FL_G/FL_B [m] Travel Distance S [m]
 FL_G =Straight Overhead FL_B =Safe Sagging Overhead

Overhead Application | Short Travel

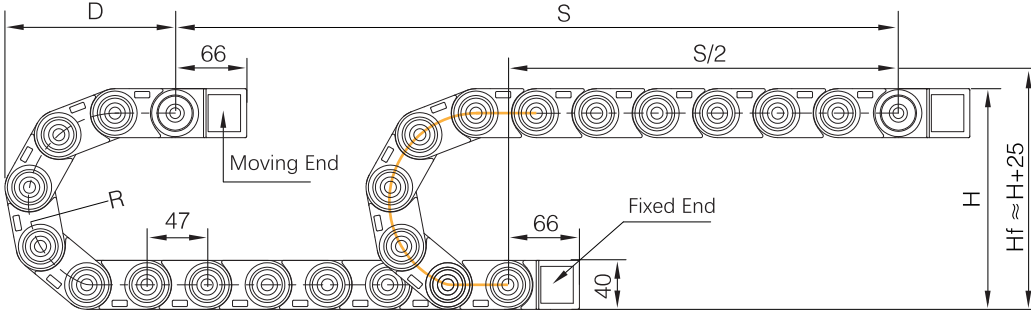

R	055	075	100	125	150
H	150	190	240	290	340
D	149	169	194	219	245
K	267	330	408	487	565

Actual Installation Height: $HF \approx H+25\text{mm}$

Sliding Application | Long Travels : $L_k = S/2 + K_1 + \Delta M$

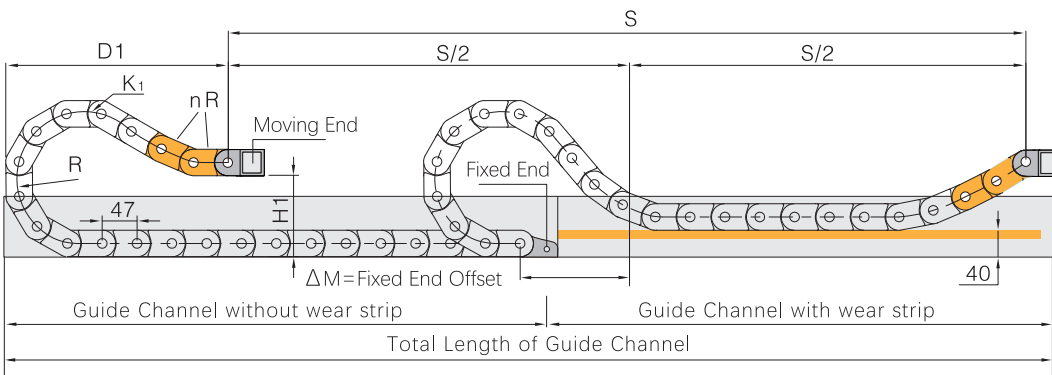

R	055	075	100	125	150
H1	130	120	120	120	120
D1	146	260	380	445	590
K1	265	415	645	736	1010
ΔC	--	115	210	240	365
nR	--	2	2	3	3

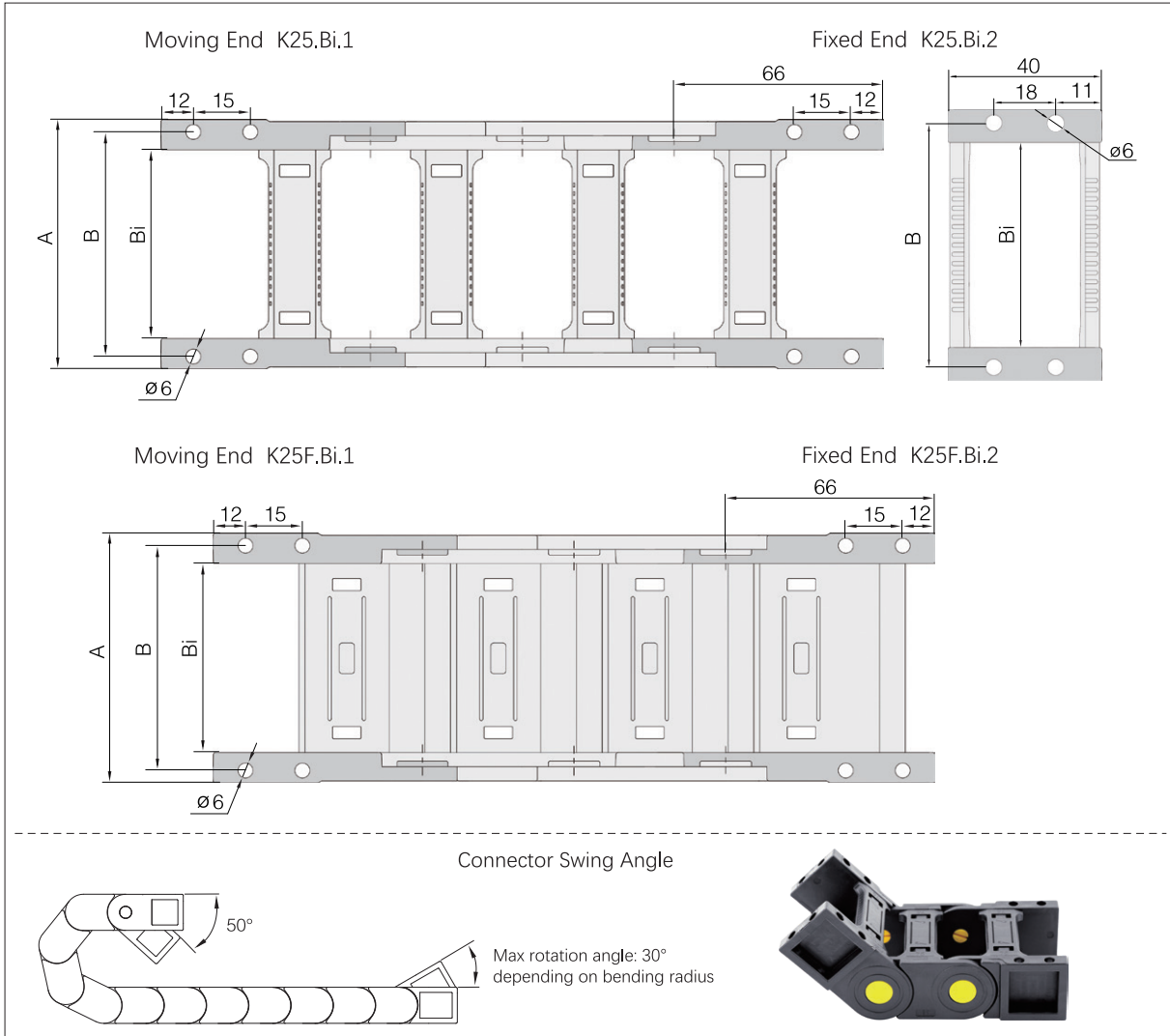

Product Code Complete Set	A [mm]	B [mm]	Bi [mm]
K.025Q.025.12	49	39	25
K.025Q.038.12	62	52	38
K.025Q.050.12	74	64	50
K.025Q.057.12	81	71	57
K.025Q.065.12	89	79	65
K.025Q.070.12	94	84	70
K.025Q.075.12	109	89	75
K.025Q.100.12	124	114	100
K.025Q.103.12	127	117	103

Product Code Complete Set	A [mm]	B [mm]	Bi [mm]
K.025F.025.12	49	39	25
K.025F.038.12	62	52	38
K.025F.050.12	74	64	50
K.025F.057.12	81	71	57
K.025F.075.12	109	89	75

Separation Principle | Vertical Divider Horizontal Divider

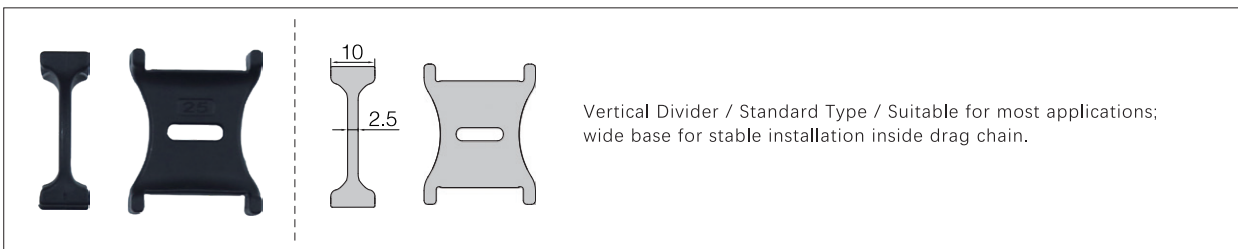
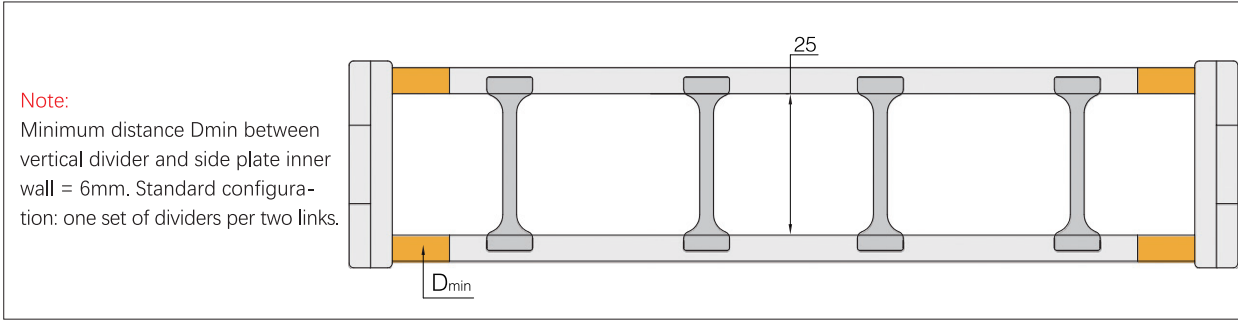

Ordering Example

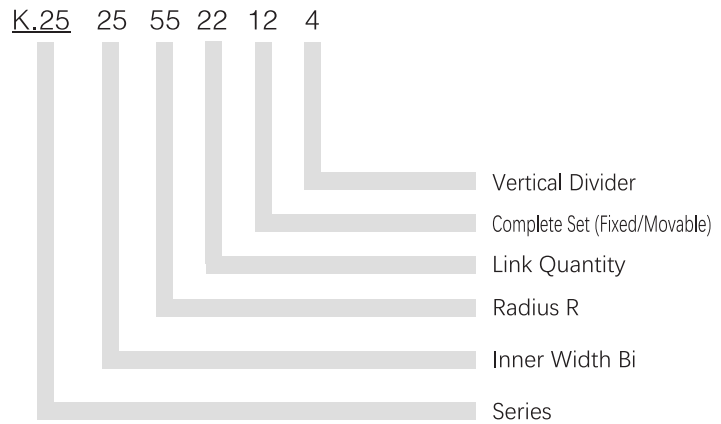
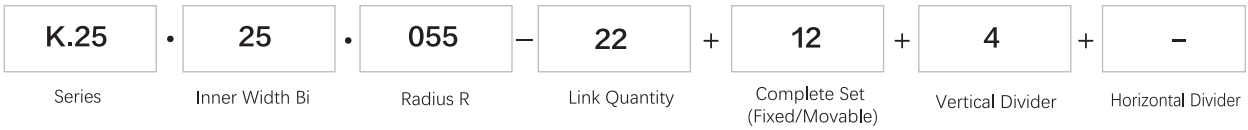

Yellow Buckle Economy 30 Series

Yellow Buckle Economy | K Series | Product Range

Wide applicability Cost-effective



Drag Chain | K Series | Bridge type, upper & lower cover openable

Product Code Drag Chain	Bi [mm]	Ba [mm]	R [mm]	Weight [kg/m]
K.30Q.25.R	25	50	055 075 100 125 150	≈1.18
K.30Q.38.R	38	63	055 075 100 125 150	≈1.25
K.30Q.50.R	50	75	055 075 100 125 150	≈1.34
K.30Q.57.R	57	82	055 075 100 125 150	≈1.36
K.30Q.65.R	65	90	055 075 100 125 150	≈1.38
K.30Q.70.R	70	95	055 075 100 125 150	≈1.42
K.30Q.75.R	75	100	055 075 100 125 150	≈1.47
K.30Q.100.R	100	125	055 075 100 125 150	≈1.50
K.30Q.103.R	103	128	055 075 100 125 150	≈1.51

Complete the model number according to the required bending radius (R), Example: K.30Q.25.R.055



Drag Chain | K Series | Fully enclosed, upper & lower cover openable

Product Code Drag Chain	Bi [mm]	Ba [mm]	R [mm]	Weight [kg/m]
K.30F.25.R	25	50	055 075 100 125 150	≈1.13
K.30F.38.R	38	63	055 075 100 125 150	≈1.44
K.30F.50.R	50	75	055 075 100 125 150	≈1.56
K.30F.57.R	57	82	055 075 100 125 150	≈1.63
K.30F.75.R	75	100	055 075 100 125 150	≈1.93

Complete the model number according to the required bending radius (R), Example: K.30F.25.R.055

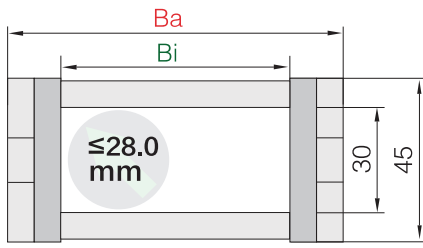

Inner [mm]	30
Height Pitch [mm/link]	47
Number /m	22
= [mm]	1034
Chain Length	$L_k = S/2 + K$

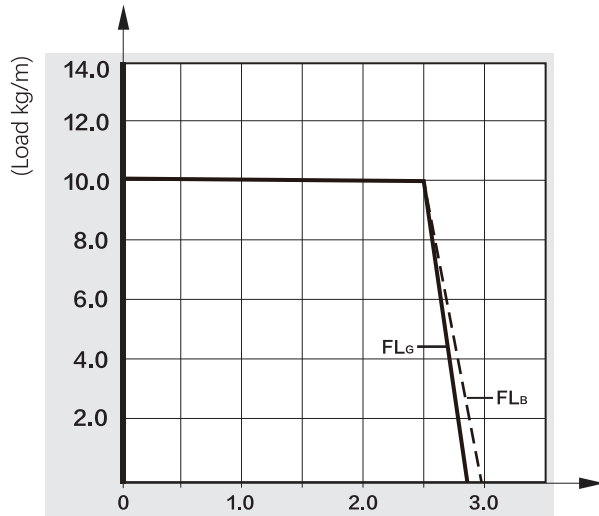

Overhead Operation FLG/FLB [m] Travel Distance S [m]
 FLG=Straight Overhead FLB=Safe Sagging Overhead

Overhead Application | Short Travel

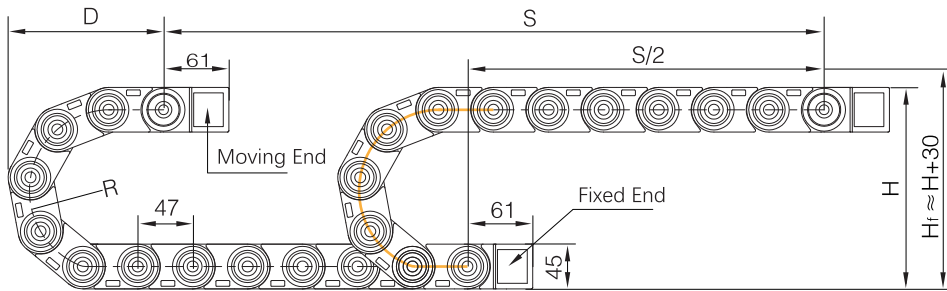

R	055	075	100	125	150
H	155	195	245	295	345
D	149	169	194	219	245
K	267	330	408	487	565

Actual Installation Height: $H_f \approx H+30\text{mm}$

Sliding Application | Long Travels: $L_k = S/2 + K_1 + \Delta M$

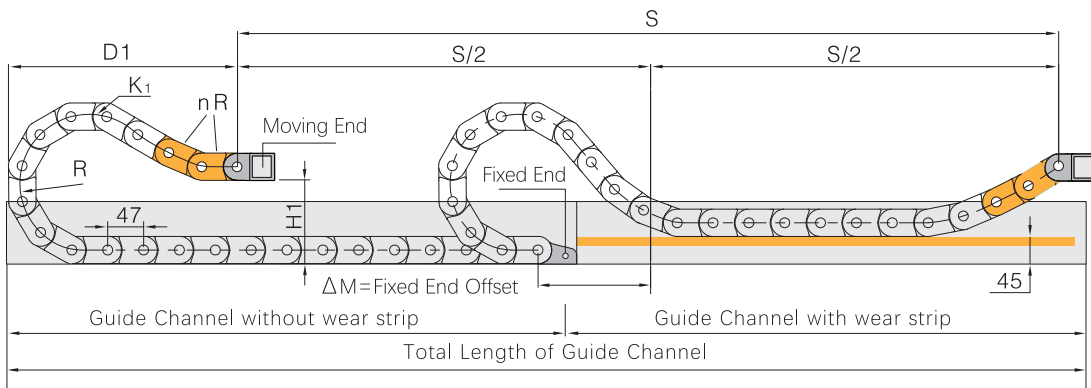

R	055	075	100	125	150
H1	140	135	135	135	135
D1	146	260	380	445	590
K1	265	415	645	736	1010
ΔC	--	115	210	240	365
nR	--	2	2	3	3

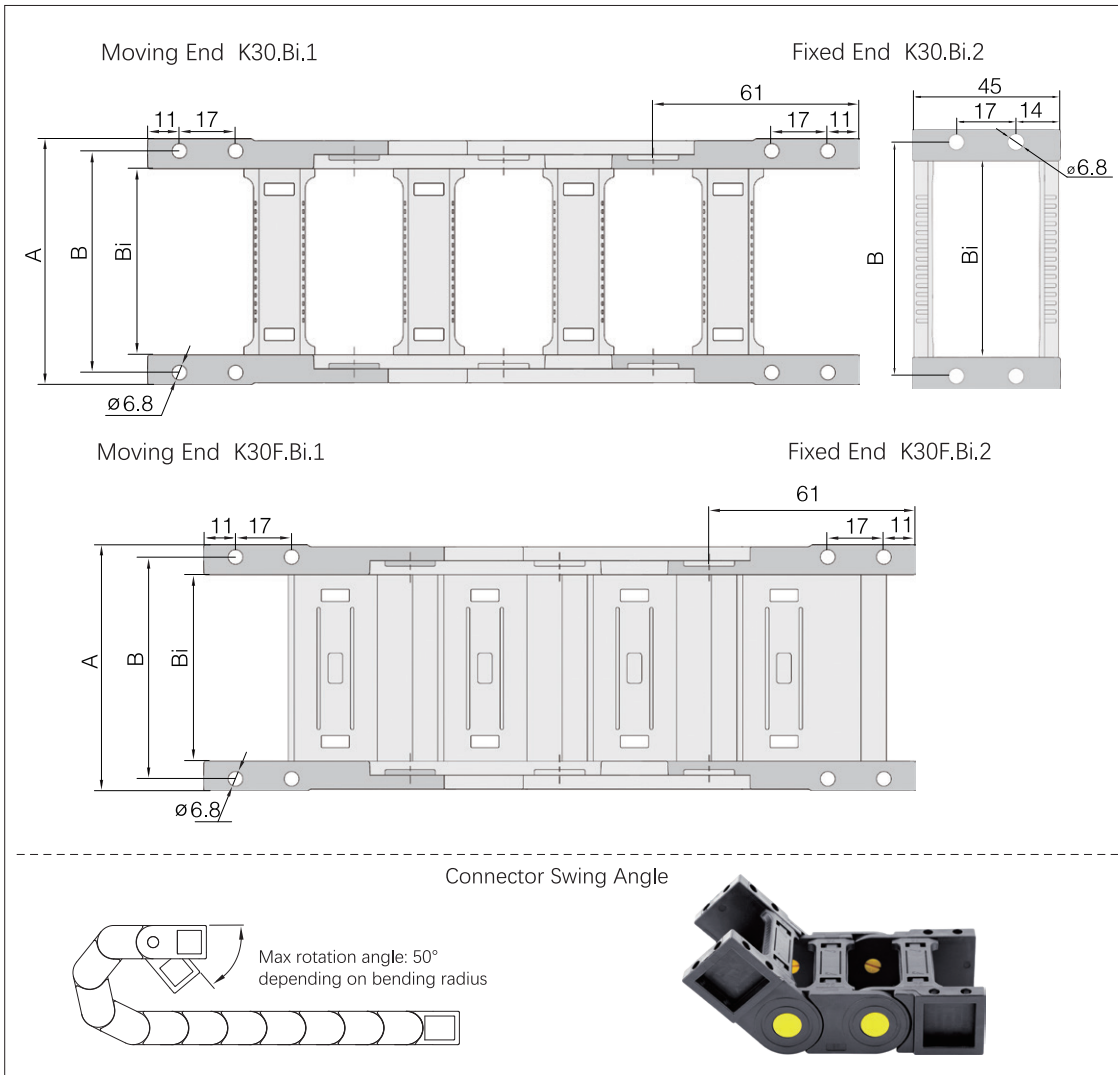

Product Code Complete Set	A [mm]	B [mm]	Bi [mm]
K.030Q.025.12	50	39	25
K.030Q.038.12	63	52	38
K.030Q.050.12	75	64	50
K.030Q.057.12	82	71	57
K.030Q.065.12	90	79	65
K.030Q.070.12	95	84	70
K.030Q.075.12	110	89	75
K.030Q.100.12	125	114	100
K.030Q.103.12	128	117	103

Product Code Complete Set	A [mm]	B [mm]	Bi [mm]
K.030F.025.12	50	39	25
K.030F.038.12	63	52	38
K.030F.050.12	75	64	50
K.030F.057.12	82	71	57
K.030F.075.12	110	89	75

Separation Principle | Vertical Divider Horizontal Divider

Note:

Minimum distance D_{min} between vertical divider and side plate inner wall = 11mm. Standard configuration: one set of dividers per two links.

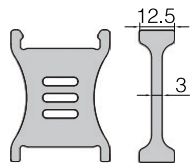
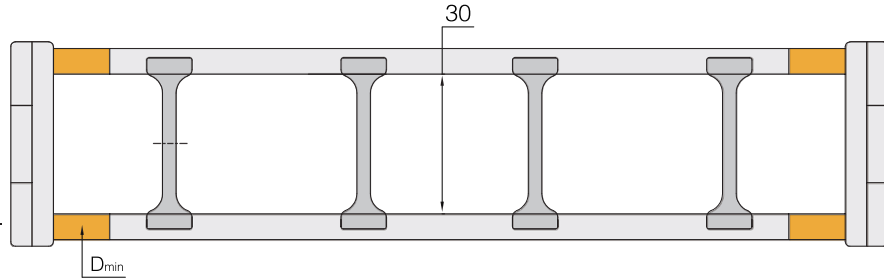

Vertical Divider / Standard Type / Suitable for most applications; wide base for stable installation inside drag chain.



Ordering Example

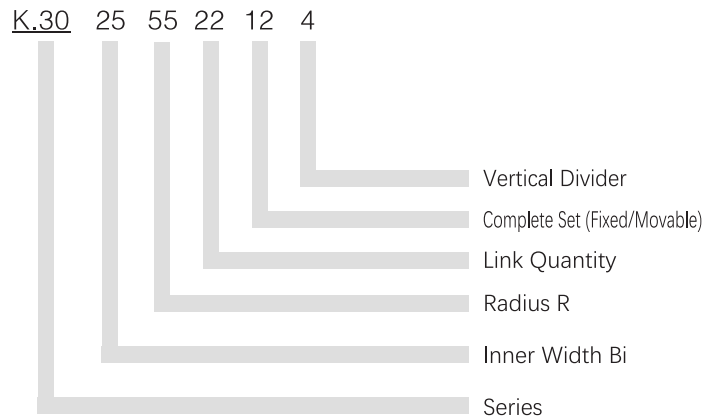
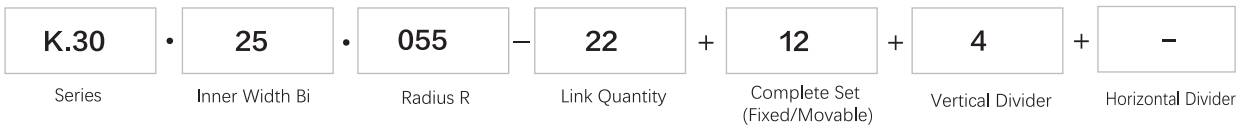

Yellow Buckle Economy 35 Series

Yellow Buckle Economy | K Series | Product Range

Wide applicability Cost-effective



Drag Chain | K Series | Bridge type, upper & lower cover openable

Product Code Drag Chain	Bi [mm]	Ba [mm]	R [mm]	Weight [kg/m]
K.35Q.50.R	50	78	075 100 125 150 175 200 250 300	≈ 1.68
K.35Q.60.R	60	88	075 100 125 150 175 200 250 300	≈ 1.77
K.35Q.65.R	65	93	075 100 125 150 175 200 250 300	≈ 1.68
K.35Q.75.R	75	103	075 100 125 150 175 200 250 300	≈ 1.84
K.35Q.100.R	100	128	075 100 125 150 175 200 250 300	≈ 1.97
K.35Q.125.R	125	153	075 100 125 150 175 200 250 300	≈ 2.13
K.35Q.150.R	150	178	075 100 125 150 175 200 250 300	≈ 2.26
K.35Q.200.R	200	228	075 100 125 150 175 200 250 300	≈ 2.64
K.35Q.250.R	250	278	075 100 125 150 175 200 250 300	≈ 3.00

Complete the model number according to the required bending radius (R), Example: K.35Q.50.R.075

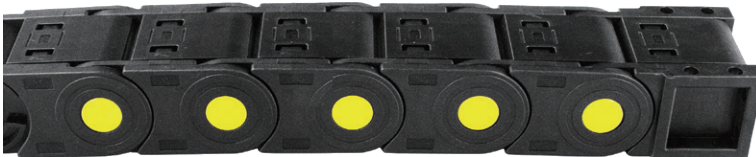

Drag Chain | K Series | Fully enclosed, upper & lower cover openable

Product Code Drag Chain	Bi [mm]	Ba [mm]	R [mm]	Weight [kg/m]
K.35F.50.R	50	78	075 100 125 150 175 200 250 300	≈ 1.86
K.35F.60.R	60	88	075 100 125 150 175 200 250 300	≈ 2.07
K.35F.65.R	65	93	075 100 125 150 175 200 250 300	≈ 2.15
K.35F.75.R	75	103	075 100 125 150 175 200 250 300	≈ 2.17
K.35F.100.R	100	128	075 100 125 150 175 200 250 300	≈ 2.48
K.35F.125.R	125	153	075 100 125 150 175 200 250 300	≈ 2.63
K.35F.150.R	150	178	075 100 125 150 175 200 250 300	≈ 3.04

Complete the model number according to the required bending radius (R), Example: K.35F.50.R.075

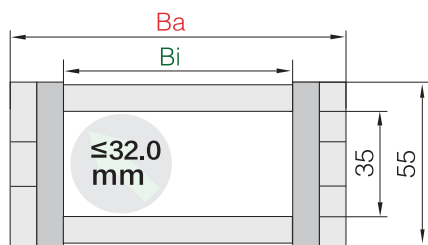

Inner [mm]	35
Height Pitch [mm/link]	67
Number /m	15
= [mm]	1005
Chain Length	$L_k = \frac{S}{2} + K$

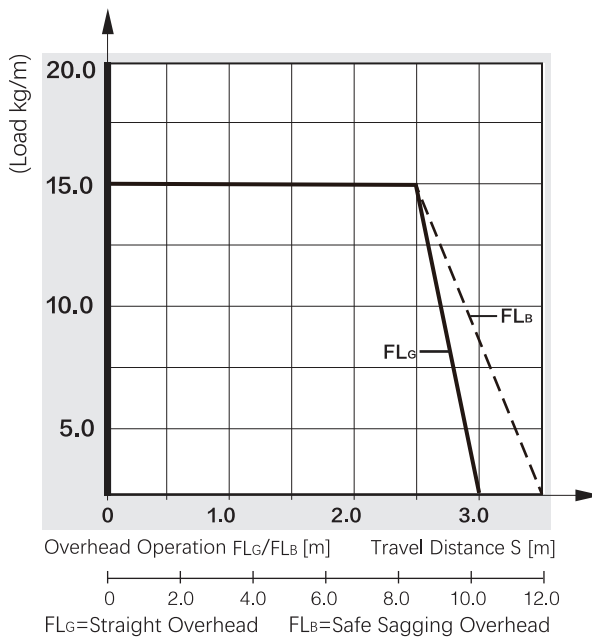

Overhead Application | Short Travel

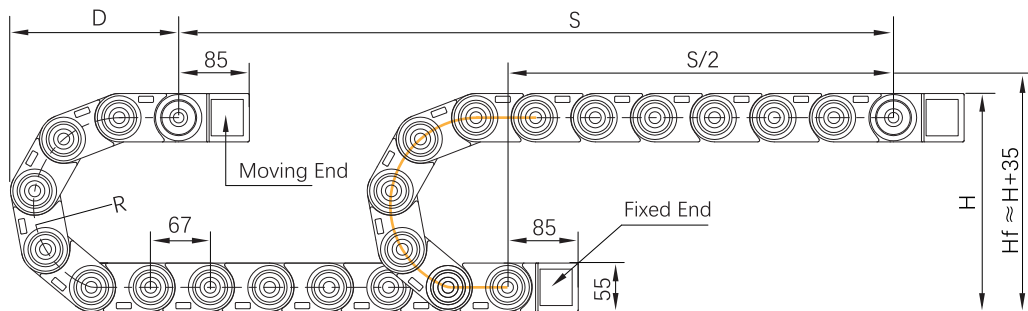

R	075	100	125	150	175	200	250	300
H	205	255	305	355	405	455	555	655
D	210	235	260	285	310	335	385	435
K	370	450	530	605	685	765	920	1080

Actual Installation Height: $H_f \approx H + 35\text{mm}$

Sliding Application | Long Travels : $L_k = S/2 + K_1 + \Delta M$

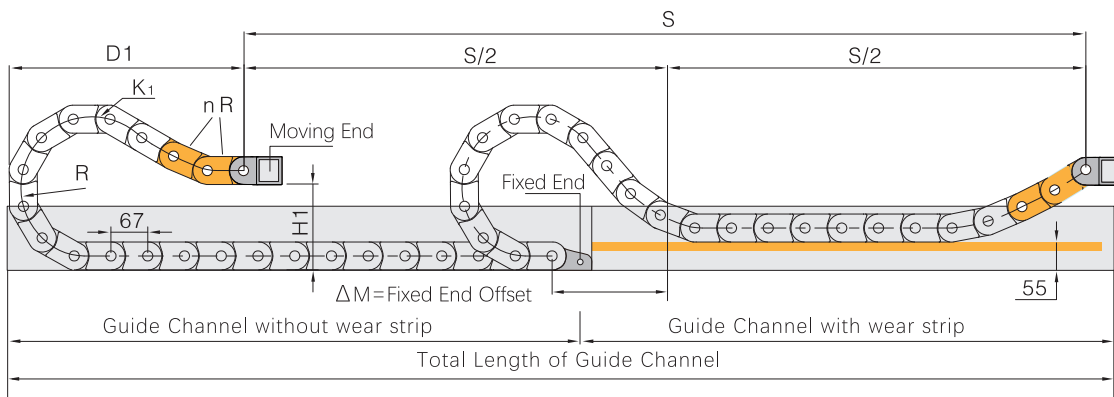

R	075	100	125	150	175	200	250	300
H1	150	165	165	165	165	165	165	165
D1	203	230	470	575	725	780	1015	1145
K1	365	445	800	1000	1130	1335	1670	1940
ΔC	--	--	235	305	445	465	645	735
nR	--	--	2	2	2	3	3	4

Yellow Buckle Economy | K Series | Installation Dimensions

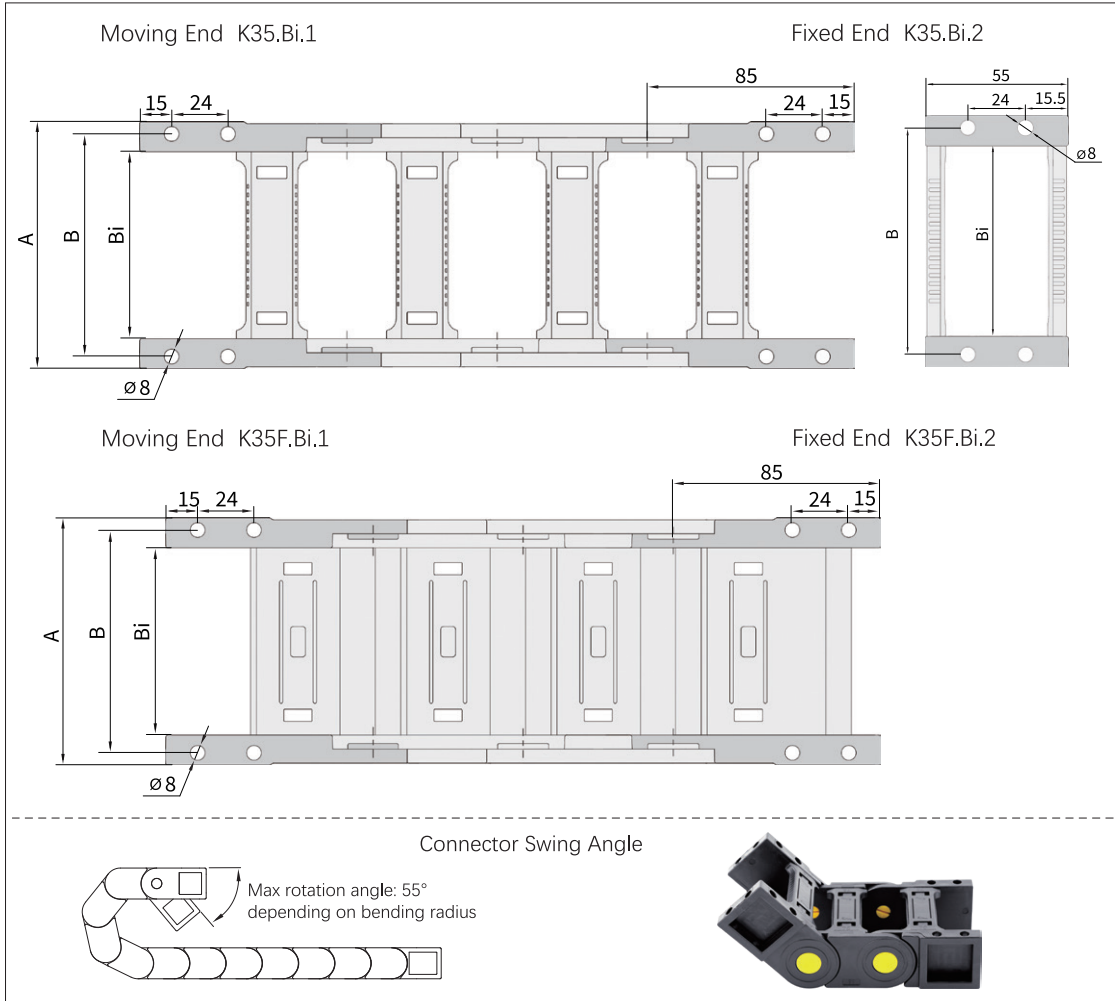

Product Code Complete Set	A [mm]	B [mm]	Bi [mm]
K.035Q.050.12	78	65	50
K.035Q.060.12	88	75	60
K.035Q.065.12	93	80	65
K.035Q.075.12	103	90	75
K.035Q.100.12	128	115	100
K.035Q.115.12	143	130	115
K.035Q.125.12	153	140	125
K.035Q.150.12	178	165	150
K.035Q.175.12	203	190	175
K.035Q.200.12	228	215	200
K.035Q.250.12	278	265	250

Product Code Complete Set	A [mm]	B [mm]	Bi [mm]
K.035F.050.12	78	65	50
K.035F.060.12	88	75	60
K.035F.065.12	93	80	65
K.035F.075.12	103	90	75
K.035F.100.12	128	115	100
K.035F.125.12	153	140	125
K.035F.150.12	178	165	150

Separation Principle | Vertical Divider Horizontal Divider

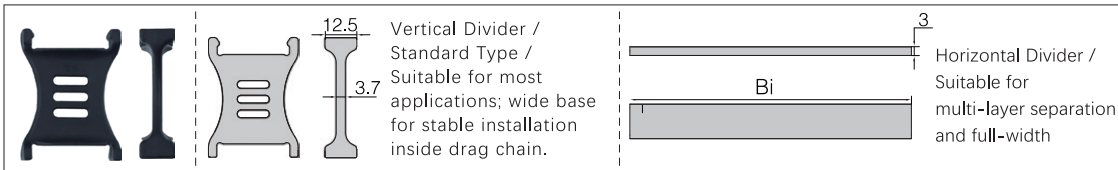
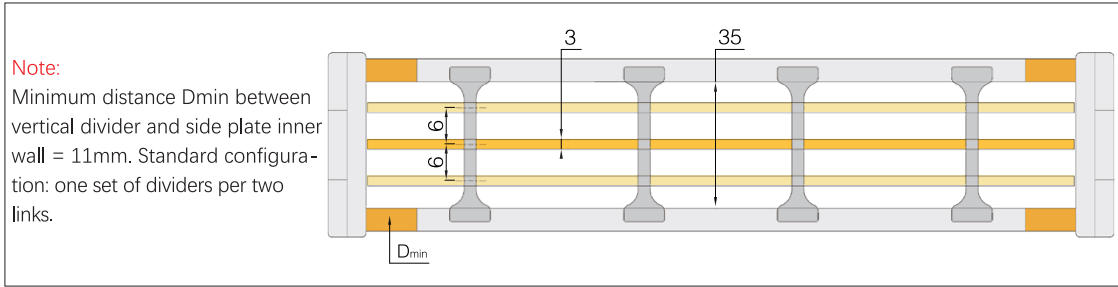

Ordering Example

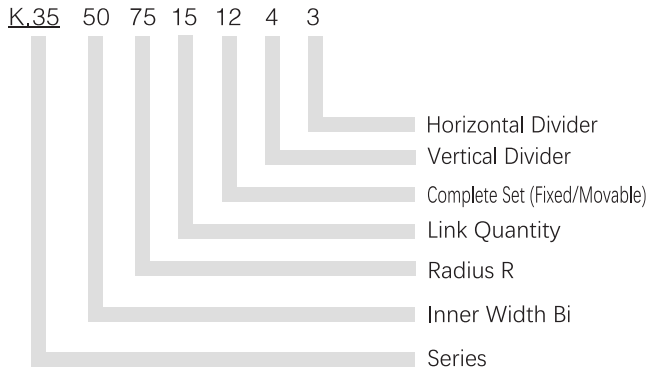
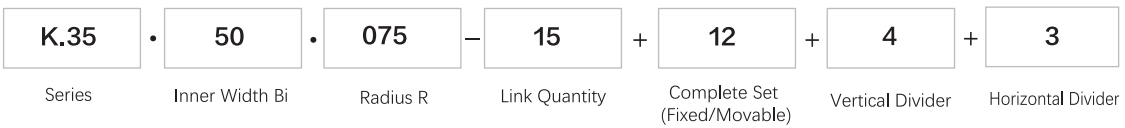

Yellow Buckle Economy | K Series | Product Range

Wide applicability Cost-effective

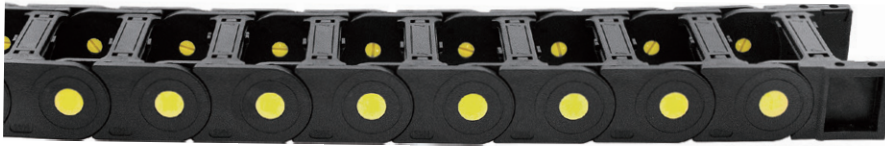

Drag Chain | K Series | Bridge type, upper & lower cover openable

Product Code Drag Chain	Bi [mm]	Ba [mm]	R [mm]	Weight [kg/m]
K.45Q.50.R	50	83	100 125 150 175 200 250 300 350	≈ 2.16
K.45Q.60.R	60	93	100 125 150 175 200 250 300 350	≈ 2.23
K.45Q.65.R	65	98	100 125 150 175 200 250 300 350	≈ 2.50
K.45Q.75.R	75	108	100 125 150 175 200 250 300 350	≈ 2.30
K.45Q.100.R	100	126	100 125 150 175 200 250 300 350	≈ 2.43
K.45Q.125.R	125	158	100 125 150 175 200 250 300 350	≈ 2.59
K.45Q.150.R	150	183	100 125 150 175 200 250 300 350	≈ 2.72
K.45Q.200.R	200	233	100 125 150 175 200 250 300 350	≈ 3.11
K.45Q.250.R	250	283	100 125 150 175 200 250 300 350	≈ 3.45

Complete the model number according to the required bending radius (R), Example: K.45Q.50.R.100



Drag Chain | K Series | Fully enclosed, upper & lower cover openable

Product Code Drag Chain	Bi [mm]	Ba [mm]	R [mm]	Weight [kg/m]
K.45F.60.R	60	86	100 125 150 175 200 250 300 350	≈ 2.35
K.45F.75.R	75	108	100 125 150 175 200 250 300 350	≈ 2.54
K.45F.100.R	100	126	100 125 150 175 200 250 300 350	≈ 2.78
K.45F.125.R	125	158	100 125 150 175 200 250 300 350	≈ 3.14
K.45F.150.R	150	183	100 125 150 175 200 250 300 350	≈ 3.46

Complete the model number according to the required bending radius (R), Example: K.45F.60.R.100

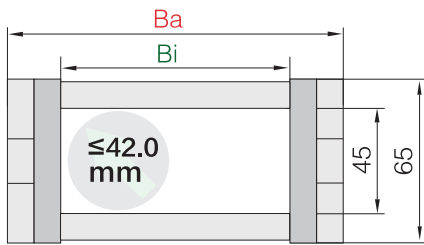

Inner [mm]	45
Height Pitch [mm/link]	80
Number /m	13
= [mm]	1040
Chain Length	$L_k = \frac{S}{2} + K$

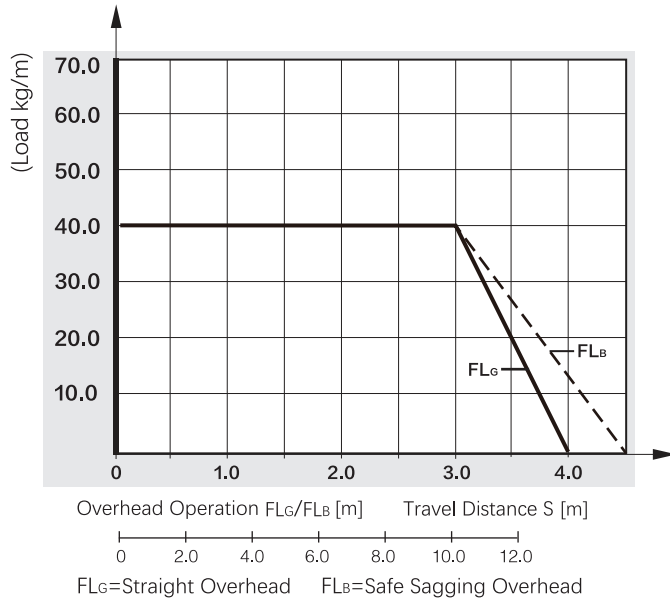

Overhead Application | Short Travel

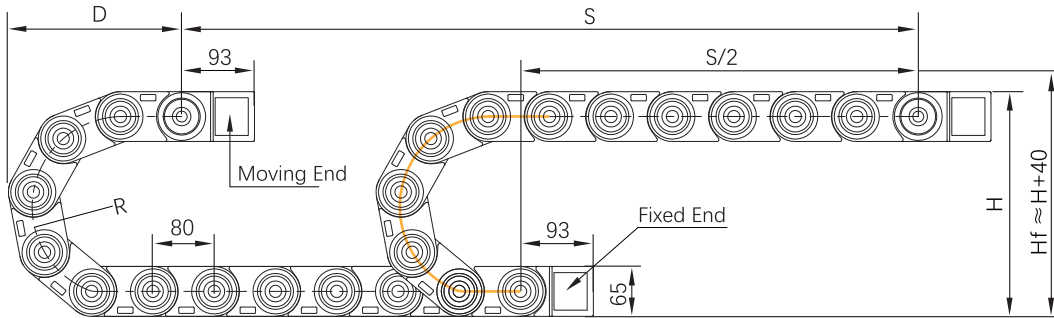

	R	100	125	150	175	200	250	300	350
H	265	315	365	415	465	565	665	665	765
D	260	285	310	335	360	410	460	460	510
K	475	553	631	710	790	977	1105	1105	1260

Actual Installation Height: $H_f \approx H + 40 \text{ mm}$

Sliding Application | Long Travels : $L_k = S/2 + K_1 + \Delta M$

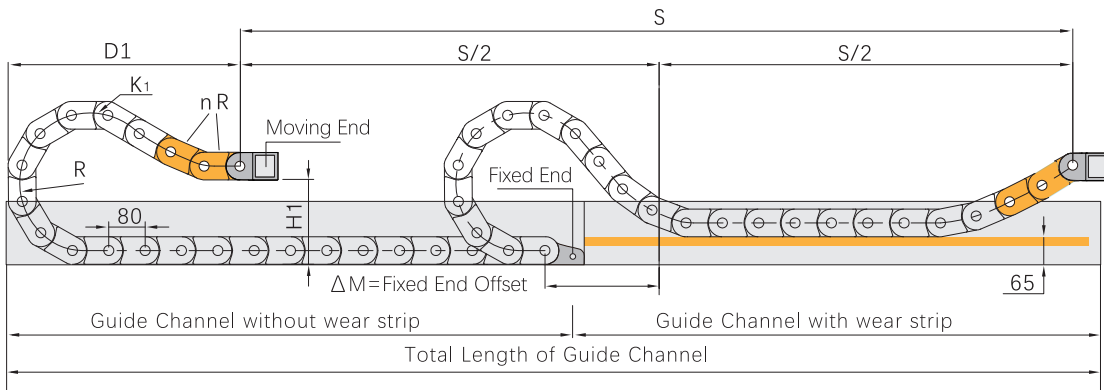

	R	100	125	150	175	200	250	300	350
H1	200	195	195	195	195	195	195	195	195
D1	260	285	505	635	780	1000	1180	1470	1470
K1	475	553	826	1000	1200	1580	1830	2230	2230
ΔC	--	--	195	300	410	600	720	970	970
nR	--	--	2	2	3	3	4	4	4

Yellow Buckle Economy | K Series | Installation Dimensions

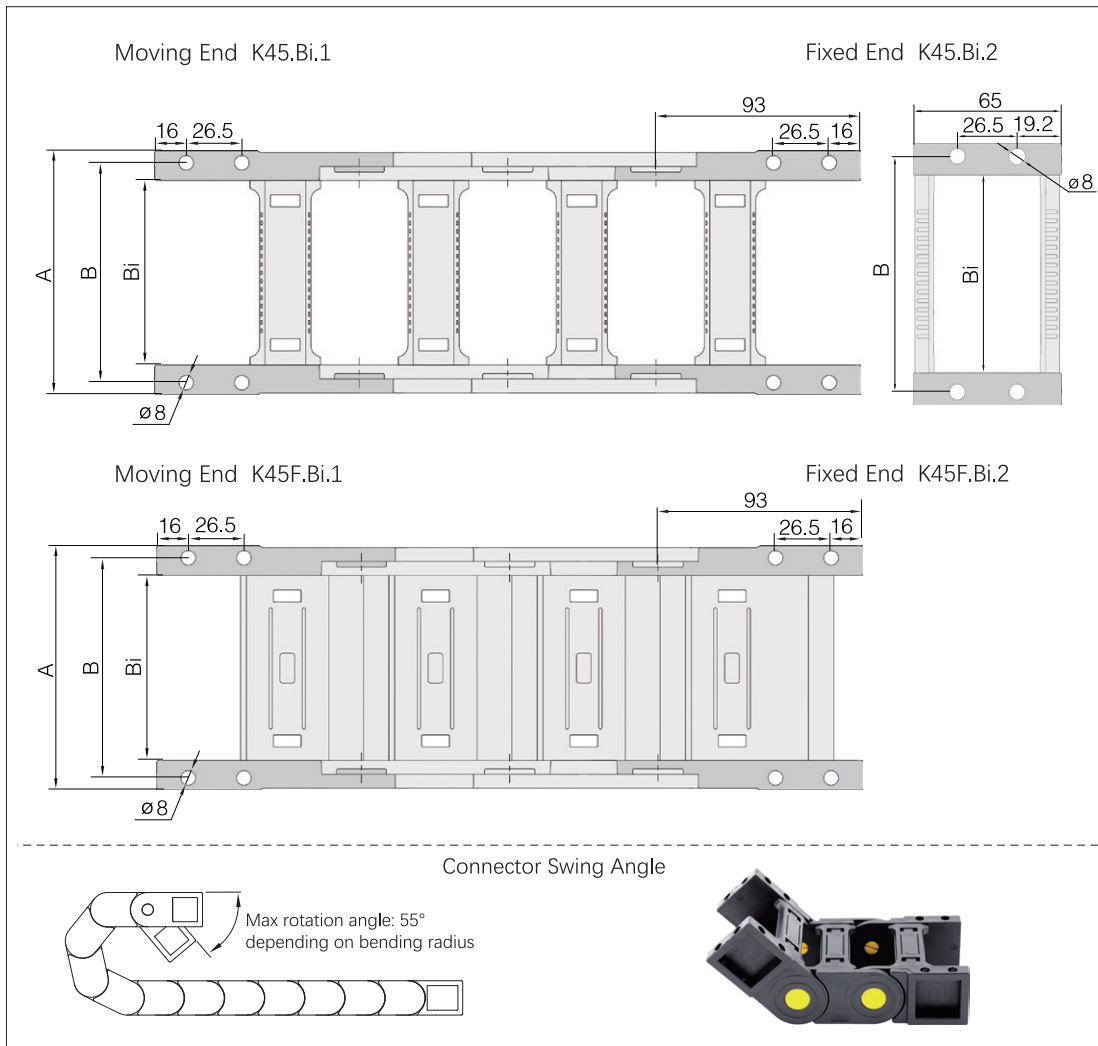

Product Code Complete Set	A [mm]	B [mm]	Bi [mm]
K.045Q.050.12	83	68	50
K.045Q.060.12	93	78	60
K.045Q.065.12	98	83	65
K.045Q.075.12	108	93	75
K.045Q.100.12	133	118	100
K.045Q.115.12	148	133	115
K.045Q.125.12	158	143	125
K.045Q.150.12	183	168	150
K.045Q.175.12	208	193	175
K.045Q.200.12	233	218	200
K.045Q.250.12	283	268	250
Product Code Complete Set	A [mm]	B [mm]	Bi [mm]
K.045F.060.12	93	78	60
K.045F.075.12	108	93	75
K.045F.100.12	133	118	100
K.045F.125.12	158	143	125
K.045F.150.12	183	168	150

Separation Principle | Vertical Divider Horizontal Divider

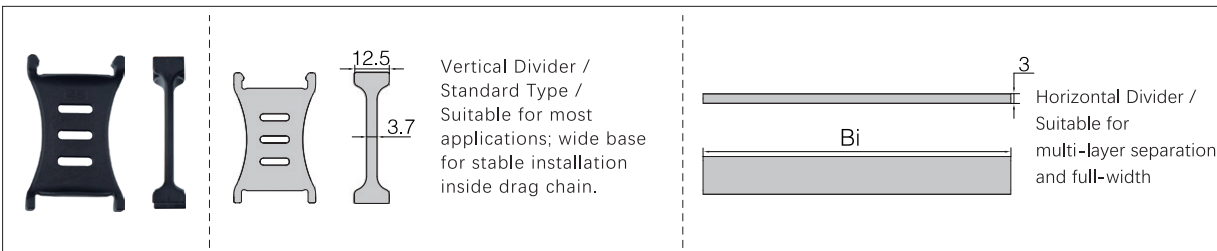
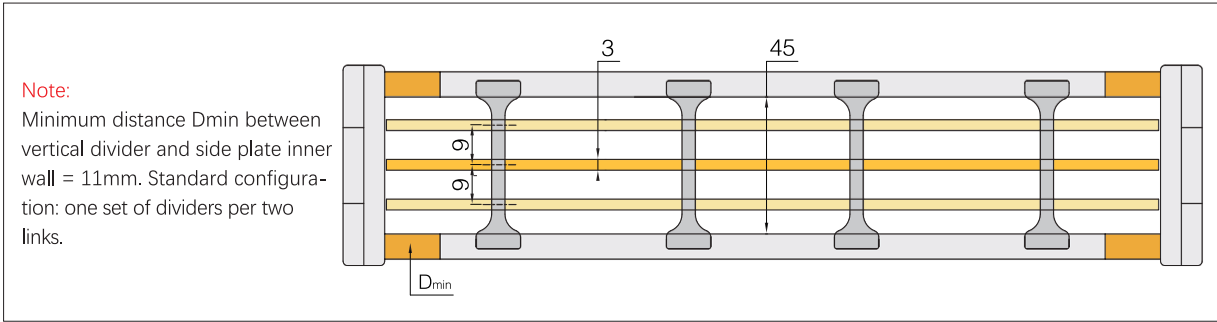

Ordering Example

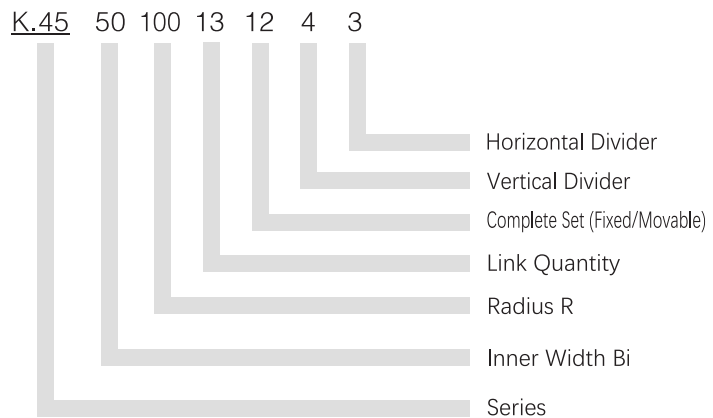
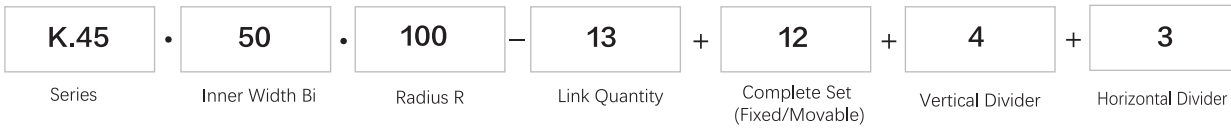

Yellow Buckle Economy | K Series | Product Range

Wide applicability Cost-effective

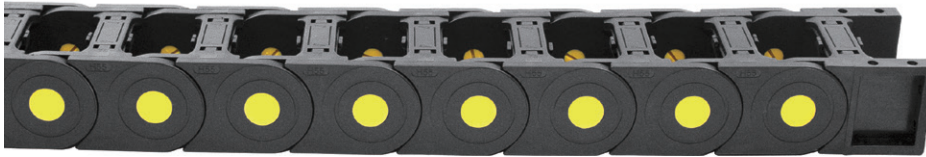

Drag Chain | K Series | Bridge type, upper & lower cover openable

Product Code Drag Chain	Bi [mm]	Ba [mm]	R [mm]	Weight [kg/m]
K.55Q.50.R	50	81	125 150 175 200 250 300	≈ 2.47
K.55Q.60.R	60	91	125 150 175 200 250 300	≈ 2.56
K.55Q.65.R	65	96	125 150 175 200 250 300	≈ 2.73
K.55Q.75.R	75	106	125 150 175 200 250 300	≈ 2.63
K.55Q.100.R	100	131	125 150 175 200 250 300	≈ 2.76
K.55Q.125.R	125	156	125 150 175 200 250 300	≈ 2.92
K.55Q.150.R	150	181	125 150 175 200 250 300	≈ 3.05
K.55Q.200.R	200	231	125 150 175 200 250 300	≈ 3.43
K.55Q.250.R	250	281	125 150 175 200 250 300	≈ 3.85

Complete the model number according to the required bending radius (R), Example: K.55Q.50.R.100



Drag Chain | K Series | Fully enclosed, upper & lower cover openable

Product Code Drag Chain	Bi [mm]	Ba [mm]	R [mm]	Weight [kg/m]
K.55F.60.R	60	91	125 150 175 200 250 300	≈ 2.68
K.55F.75.R	75	106	125 150 175 200 250 300	≈ 2.87
K.55F.100.R	100	131	125 150 175 200 250 300	≈ 3.11
K.55F.125.R	125	156	125 150 175 200 250 300	≈ 3.47
K.55F.150.R	150	181	125 150 175 200 250 300	≈ 3.78

Complete the model number according to the required bending radius (R), Example: K.55F.60.R.100

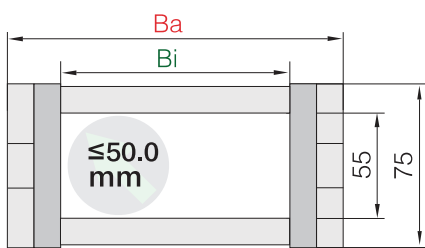

Inner [mm]	55
Height Pitch [mm/link]	80
Number /m	13
= [mm]	1040
Chain Length	$L_k = S/2 + K$

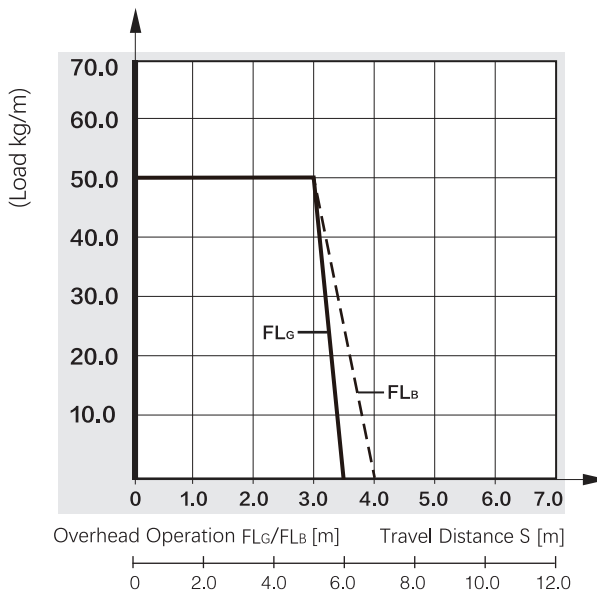

Overhead Operation FLG/FLB [m] Travel Distance S [m]
 0 2.0 4.0 6.0 8.0 10.0 12.0
 FLG=Straight Overhead FLB=Safe Sagging Overhead

Overhead Application | Short Travel

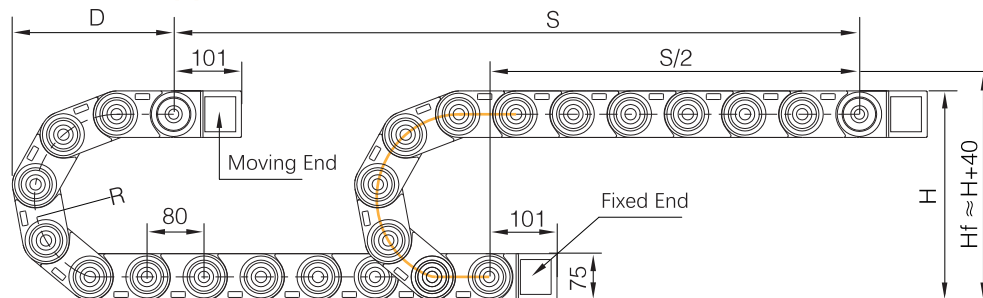

R	125	150	175	200	250	300
H	325	375	425	475	575	675
D	285	310	335	360	410	460
K	553	631	710	790	977	1105

Actual Installation Height: $H_f \approx H + 40 \text{ mm}$

Sliding Application | Long Travels : $L_k = S/2 + K_1 + \Delta M$

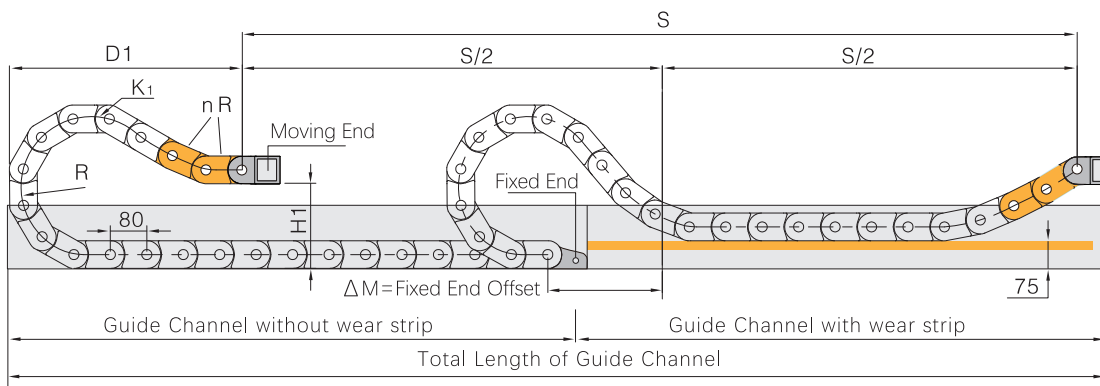

R	125	150	175	200	250	300
H1	225	225	225	225	225	225
D1	285	505	635	780	1000	1180
K1	553	826	1000	1200	1580	1830
ΔC	--	195	300	410	600	720
nR	--	2	2	3	3	4

Yellow Buckle Economy | K Series | Installation Dimensions

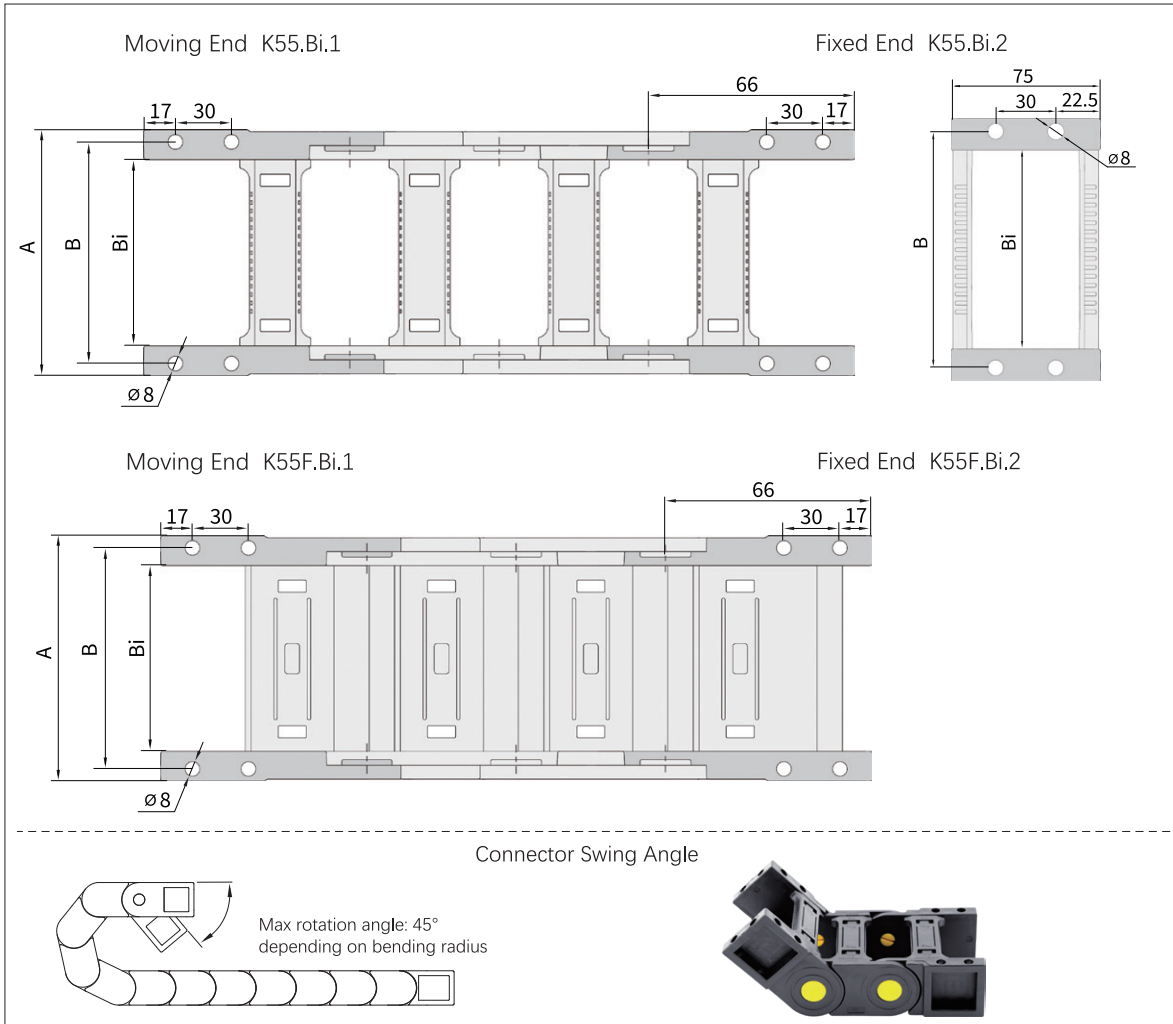

Product Code Complete Set	A [mm]	B [mm]	Bi [mm]
K.055Q.050.12	81	68	50
K.055Q.060.12	91	78	60
K.055Q.065.12	96	83	65
K.055Q.075.12	106	93	75
K.055Q.100.12	131	118	100
K.055Q.115.12	146	133	115
K.055Q.125.12	156	143	125
K.055Q.150.12	181	168	150
K.055Q.175.12	206	193	175
K.055Q.200.12	231	218	200
K.055Q.250.12	281	268	250

Product Code Complete Set	A [mm]	B [mm]	Bi [mm]
K.055F.060.12	91	78	60
K.055F.075.12	106	93	75
K.055F.100.12	131	118	100
K.055F.125.12	156	143	125
K.055F.150.12	181	168	150

Separation Principle | Vertical Divider Horizontal Divider

Note:

Minimum distance D_{min} between vertical divider and side plate inner wall = 11mm. Standard configuration: one set of dividers per two links.

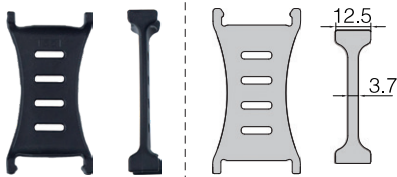
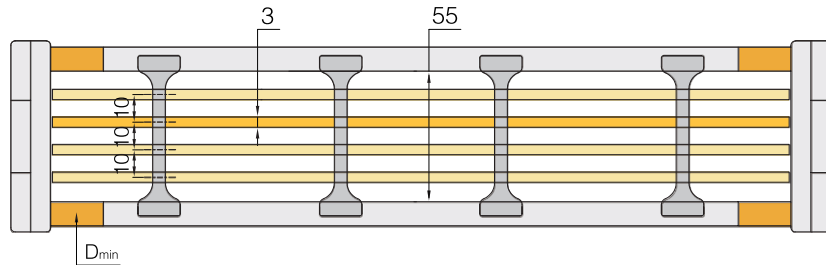

Vertical Divider / Standard Type / Suitable for most applications; wide base for stable installation inside drag chain.

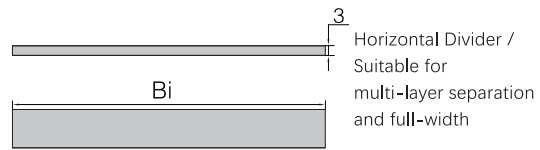

Horizontal Divider / Suitable for multi-layer separation and full-width

Ordering Example

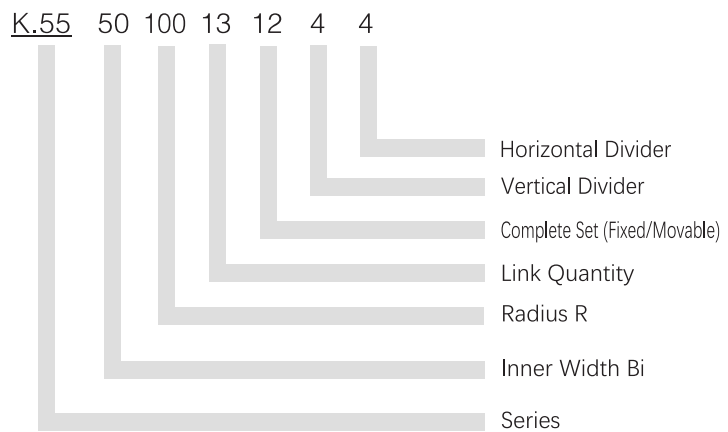
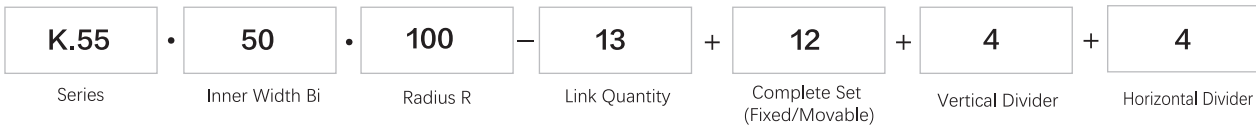

Yellow Buckle Heavy Duty 35 Series

Yellow Buckle Heavy Duty | Z Series | Product Range

Rigid structure Heavy load capacity



Drag Chain | Z Series | Bridge type, upper & lower cover openable

Product Code Drag Chain	Bi [mm]	Ba [mm]	R [mm]	Weight [kg/m]
Z.35Q.50.R	50	80	075 100 125 150 175 200 250 300	≈ 2.00
Z.35Q.75.R	75	105	075 100 125 150 175 200 250 300	≈ 2.11
Z.35Q.100.R	100	130	075 100 125 150 175 200 250 300	≈ 2.19
Z.35Q.125.R	125	155	075 100 125 150 175 200 250 300	≈ 2.41
Z.35Q.150.R	150	180	075 100 125 150 175 200 250 300	≈ 2.50
Z.35Q.200.R	200	230	075 100 125 150 175 200 250 300	≈ 2.77

Complete the model number according to the required bending radius (R), Example: Z.35Q.50.R.075



Drag Chain | Z Series | Fully enclosed, upper & lower cover openable

Product Code Drag Chain	Bi [mm]	Ba [mm]	R [mm]	Weight [kg/m]
Z.35F.50.R	50	80	075 100 125 150 175 200 250 300	≈ 2.22
Z.35F.60.R	60	90	075 100 125 150 175 200 250 300	≈ 2.33
Z.35F.75.R	75	105	075 100 125 150 175 200 250 300	≈ 2.51
Z.35F.100.R	100	130	075 100 125 150 175 200 250 300	≈ 2.69
Z.35F.150.R	150	180	-- 100 125 150 175 200 250 300	≈ 3.22

Complete the model number according to the required bending radius (R), Example: Z.35F.50.R.075

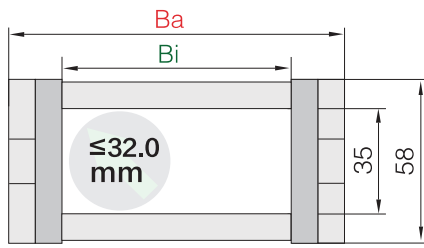

Inner [mm]	35
Height Pitch [mm/link]	66
Number /m	15
= [mm]	990
Chain Length	$L_k = \frac{S}{2} + K$

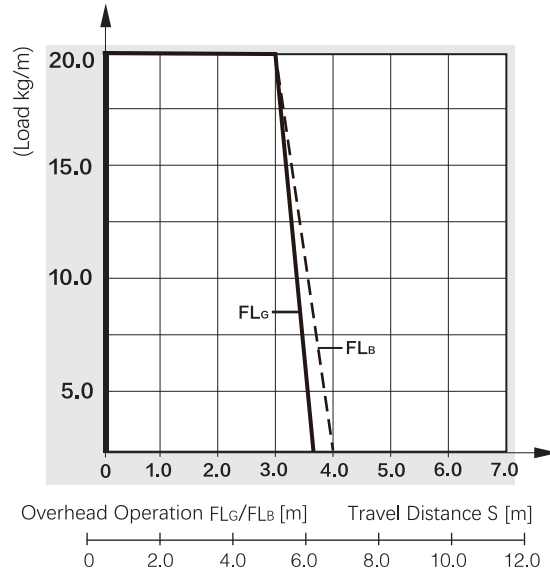

Overhead Operation FL_G/FL_B [m] Travel Distance S [m]
 FL_G =Straight Overhead FL_B =Safe Sagging Overhead

Overhead Application | Short Travel

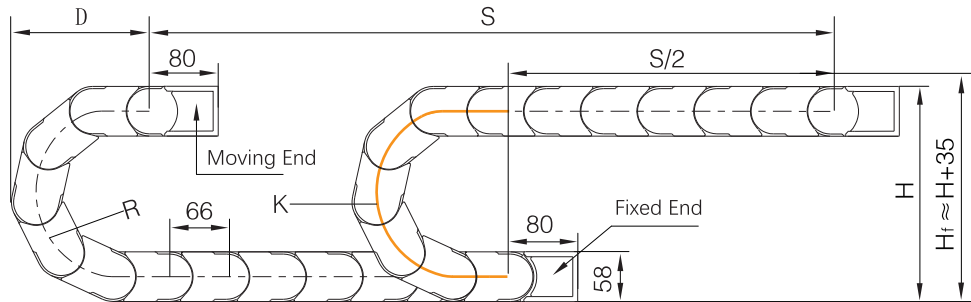

R	075	100	125	150	175	200	250	300
H	208	258	308	358	408	458	558	658
D	207	232	257	282	307	332	382	432
K	368	446	525	603	682	760	917	1074

Actual Installation Height: $H_F \approx H + 35\text{mm}$

Sliding Application | Long Travels : $L_k = S/2 + K_1 + \Delta M$

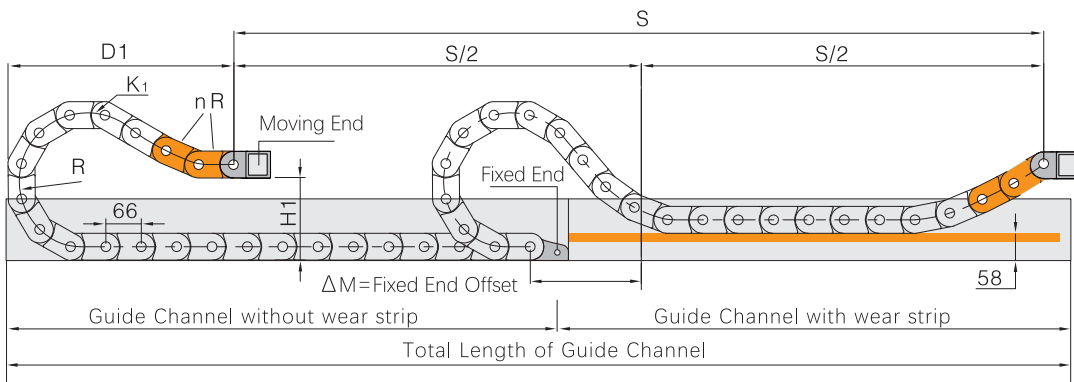

R	075	100	125	150	175	200	250	300
H1	150	175	175	175	175	175	175	175
D1	208	233	476	575	675	785	1015	1150
K1	370	450	805	1010	1180	1345	1675	1345
ΔC	--	--	235	305	385	465	645	735
nR	--	--	2	2	2	3	3	4

Yellow Buckle Heavy Duty | Z Series | Installation Dimensions

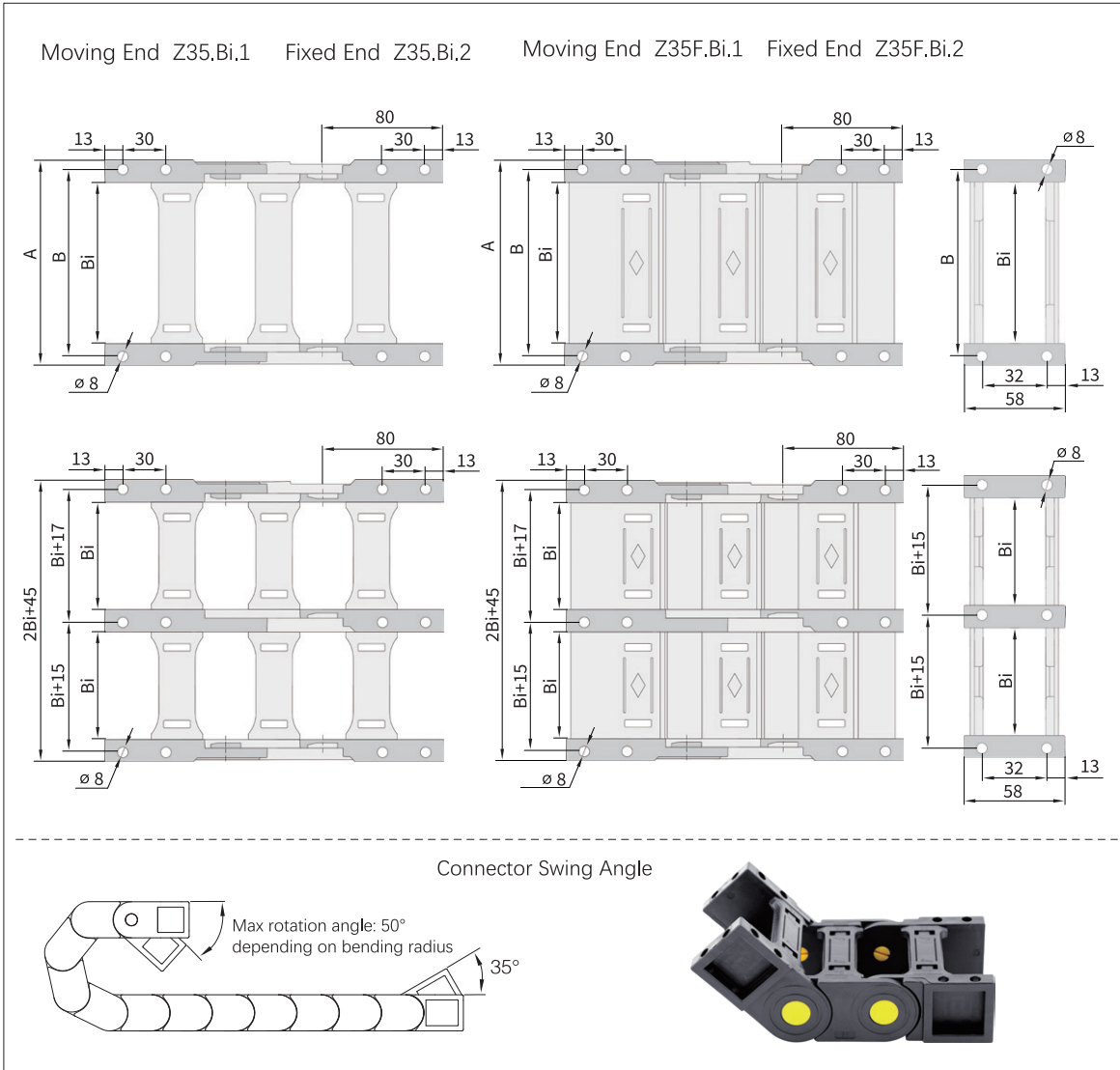

Product Code Complete Set	A [mm]	B [mm]	Bi [mm]
Z.035Q.050.12	80	67	50
Z.035Q.075.12	105	92	75
Z.035Q.100.12	130	117	100
Z.035Q.125.12	155	142	125
Z.035Q.150.12	180	167	150
Z.035Q.200.12	230	217	200

Product Code Complete Set	A [mm]	B [mm]	Bi [mm]
Z.035F.050.12	80	67	50
Z.035F.060.12	90	77	60
Z.035F.075.12	105	92	75
Z.035F.100.12	130	117	100
Z.035F.150.12	180	167	150

Separation Principle | Vertical Divider Horizontal Divider

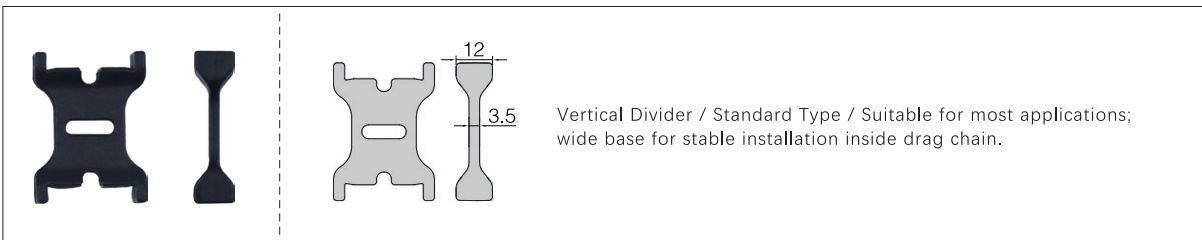
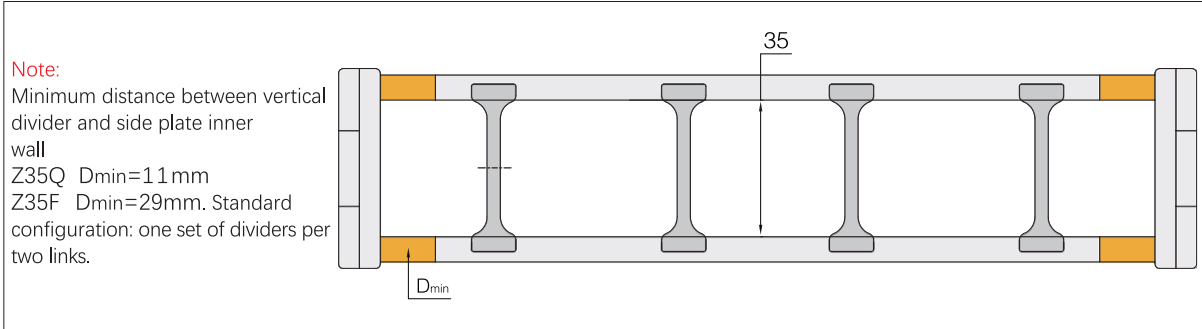

Ordering Example

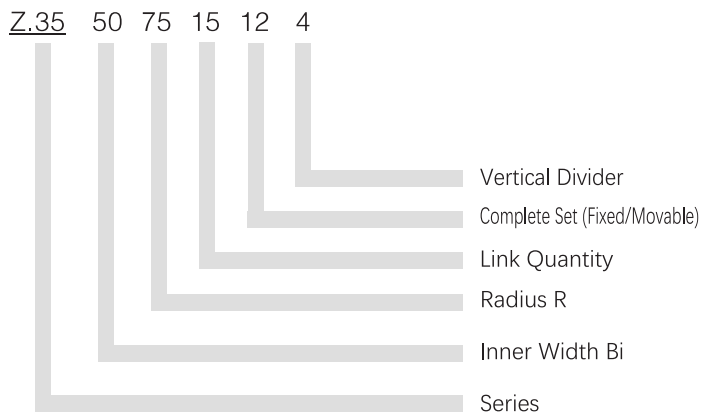
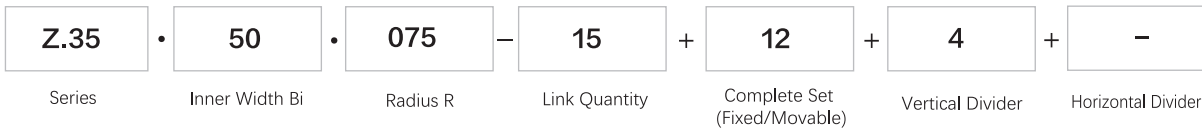

Yellow Buckle Heavy Duty | Z Series | Product Range

Rigid structure Heavy load capacity



Drag Chain | Z Series | Bridge type, upper & lower cover openable

Product Code Drag Chain	Bi [mm]	Ba [mm]	R [mm]	Weight [kg/m]
Z.45Q.50.R	50	80	075 100 125 150 175 200 250 300	≈ 2.26
Z.45Q.75.R	75	105	075 100 125 150 175 200 250 300	≈ 2.37
Z.45Q.100.R	100	130	075 100 125 150 175 200 250 300	≈ 2.45
Z.45Q.125.R	125	155	075 100 125 150 175 200 250 300	≈ 2.67
Z.45Q.150.R	150	180	075 100 125 150 175 200 250 300	≈ 2.76
Z.45Q.200.R	200	230	075 100 125 150 175 200 250 300	≈ 3.02

Complete the model number according to the required bending radius (R), Example: Z.45Q.50.R.075



Drag Chain | Z Series | Fully enclosed, upper & lower cover openable

Product Code Drag Chain	Bi [mm]	Ba [mm]	R [mm]	Weight [kg/m]
Z.45F.50.R	50	80	075 100 125 150 175 200 250 300	≈ 2.48
Z.45F.60.R	60	90	075 100 125 150 175 200 250 300	≈ 2.54
Z.45F.75.R	75	105	075 100 125 150 175 200 250 300	≈ 2.77
Z.45F.100.R	100	130	075 100 125 150 175 200 250 300	≈ 2.95
Z.45F.150.R	150	180	-- 100 125 150 175 200 250 300	≈ 3.46

Complete the model number according to the required bending radius (R), Example: Z.45F.50.R.075

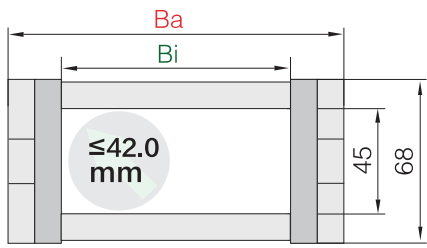

Inner [mm]	45
Height Pitch [mm/link]	66
Number /m	15
= [mm]	990
Chain Length	$L_k = S/2 + K$

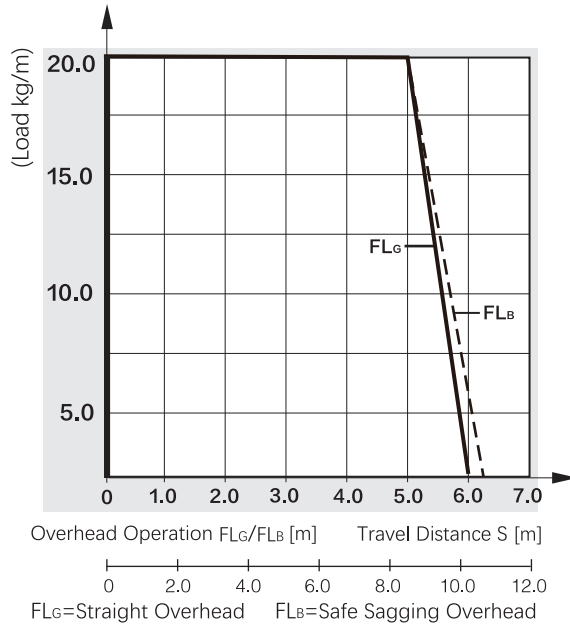

Overhead Application | Short Travel

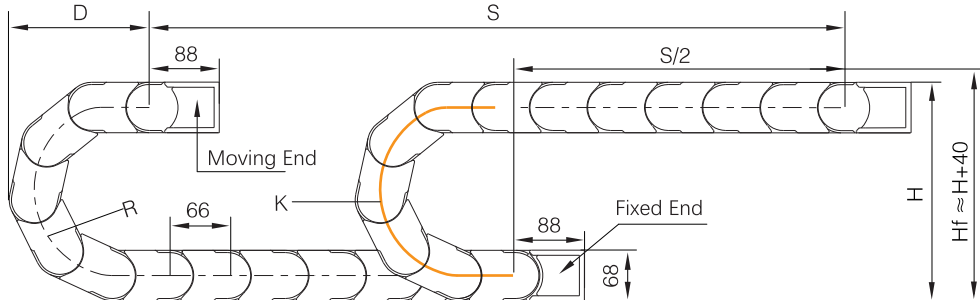

R	075	100	125	150	175	200	250	300
H	218	268	318	368	418	468	568	668
D	207	232	257	282	307	332	382	432
K	368	446	525	603	682	760	917	1074

Actual Installation Height: $HF \approx H + 40\text{mm}$

Sliding Application | Long Travels : $L_k = S/2 + K_1 + \Delta M$

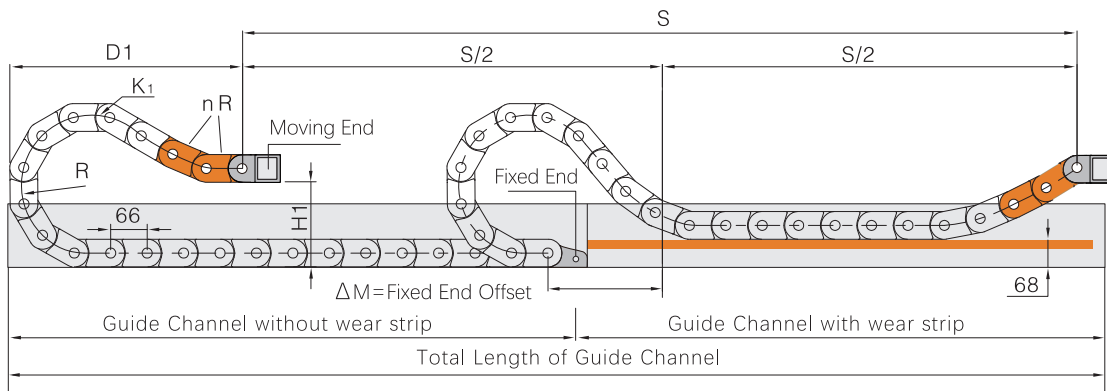

R	075	100	125	150	175	200	250	300
H1	150	175	175	175	175	175	175	175
D1	208	233	476	575	675	785	1015	1150
K1	370	450	805	1010	1180	1345	1675	1345
ΔC	--	--	235	305	385	465	645	735
nR	--	--	2	2	2	3	3	4

Yellow Buckle Heavy Duty | Z Series | Installation Dimensions

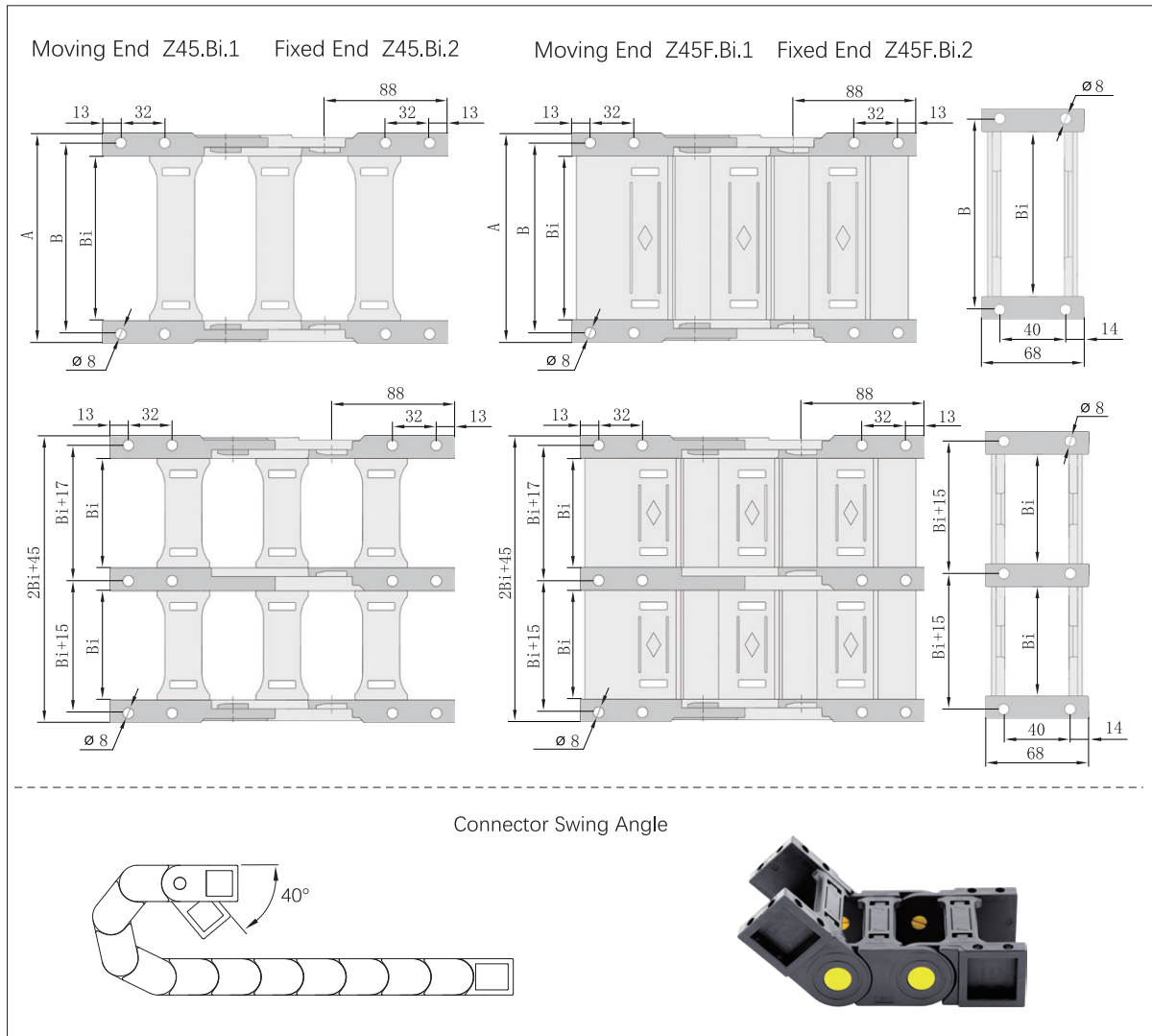

Product Code Complete Set	A [mm]	B [mm]	Bi [mm]
Z.045Q.050.12	80	67	50
Z.045Q.075.12	105	92	75
Z.045Q.100.12	130	117	100
Z.045Q.125.12	155	142	125
Z.045Q.150.12	180	167	150
Z.045Q.200.12	230	217	200

Product Code Complete Set	A [mm]	B [mm]	Bi [mm]
Z.045F.050.12	80	67	50
Z.045F.060.12	90	77	60
Z.045F.075.12	105	92	75
Z.045F.100.12	130	117	100
Z.045F.150.12	180	167	150

Separation Principle | Vertical Divider Horizontal Divider

Note:

Minimum distance between vertical divider and side plate inner wall
 Z35Q Dmin=11mm
 Z35F Dmin=29mm. Standard configuration: one set of dividers per two links.

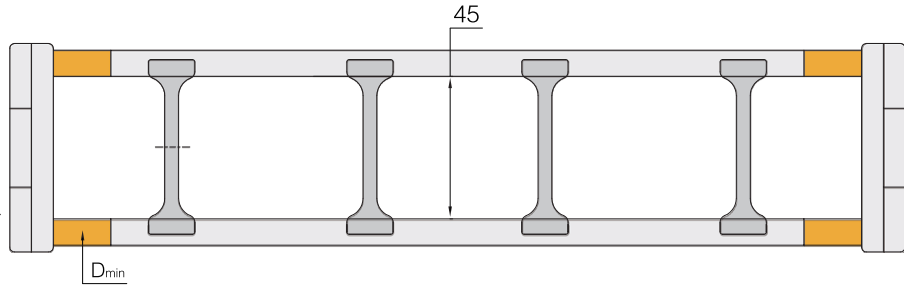

Yellow Buckle Heavy Duty Series

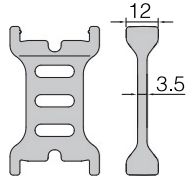

Vertical Divider / Standard Type / Suitable for most applications; wide base for stable installation inside drag chain.

Ordering Example

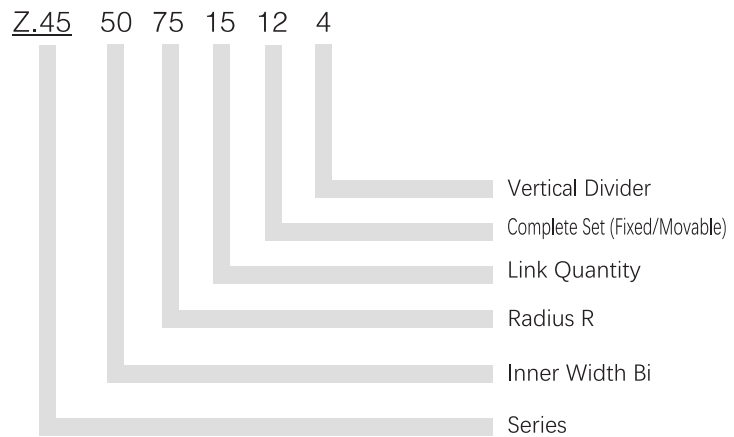
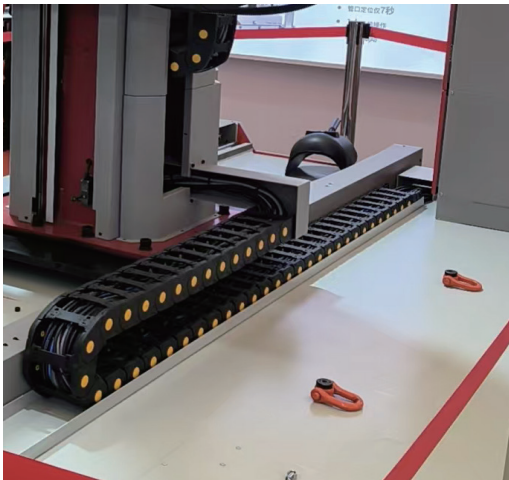
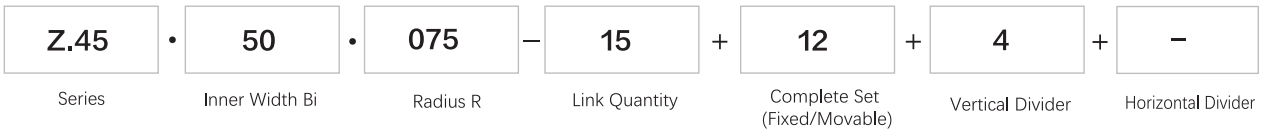

Yellow Buckle Heavy Duty 56 Series

Yellow Buckle Heavy Duty | Z Series | Product Range

Rigid structure Heavy load capacity



Drag Chain | Z Series | Bridge type, upper & lower cover openable

Product Code Drag Chain	Bi [mm]	Ba [mm]	R [mm]	Weight [kg/m]
Z.56Q.60.R	60	102	125 150 200 250 300	≈ 3.53
Z.56Q.95.R	95	137	125 150 200 250 300	≈ 3.84
Z.56Q.125.R	125	167	125 150 200 250 300	≈ 4.05
Z.56Q.150.R	150	192	125 150 200 250 300	≈ 4.11
Z.56Q.175.R	175	217	125 150 200 250 300	≈ 4.34
Z.56Q.200.R	200	242	125 150 200 250 300	≈ 4.48
Z.56Q.225.R	225	267	125 150 200 250 300	≈ 4.82
Z.56Q.250.R	250	292	125 150 200 250 300	≈ 5.13
Z.56Q.300.R	300	342	125 150 200 250 300	≈ 5.48

Complete the model number according to the required bending radius (R), Example: Z.56Q.60.R.125



Drag Chain | Z Series | Fully enclosed, upper & lower cover openable

Product Code Drag Chain	Bi [mm]	Ba [mm]	R [mm]	Weight [kg/m]
Z.56F.100.R	100	142	125 150 200 250 300	≈ 4.22
Z.56F.150.R	150	192	125 150 200 250 300	≈ 4.64
Z.56F.200.R	200	242	125 150 200 250 300	≈ 5.68

Complete the model number according to the required bending radius (R), Example: Z.56F.100.R.125

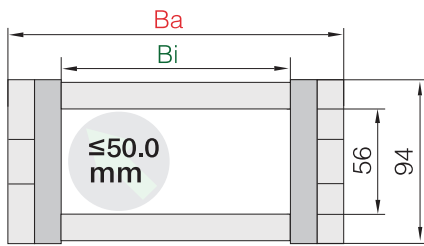

Inner [mm]	56
Height Pitch [mm/link]	90
Number /m	11
= [mm]	990
Chain Length	$L_k = S/2 + K$

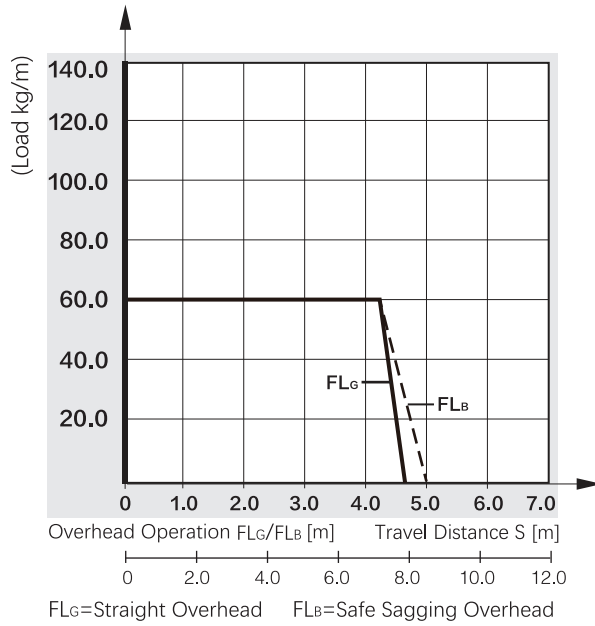

Overhead Application | Short Travel

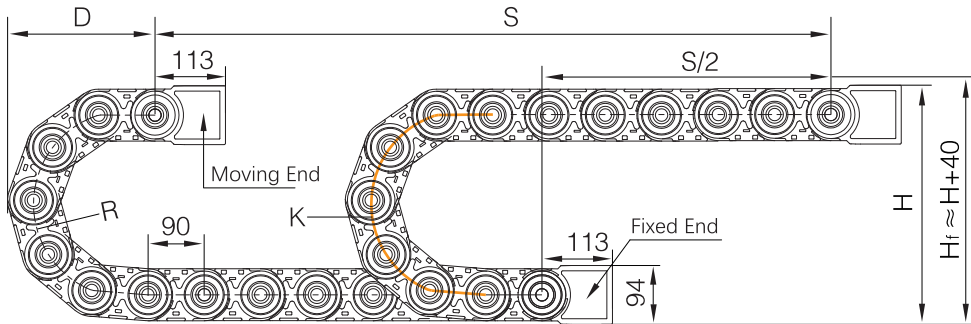

	125	150	200	250	300
R	125	150	200	250	300
H	344	394	494	594	694
D	306	330	380	430	480
K	575	650	810	965	1125

Actual Installation Height: $H_f \approx H+40\text{mm}$

Sliding Application | Long Travels : $L_k = S/2 + K_1 + \Delta M$

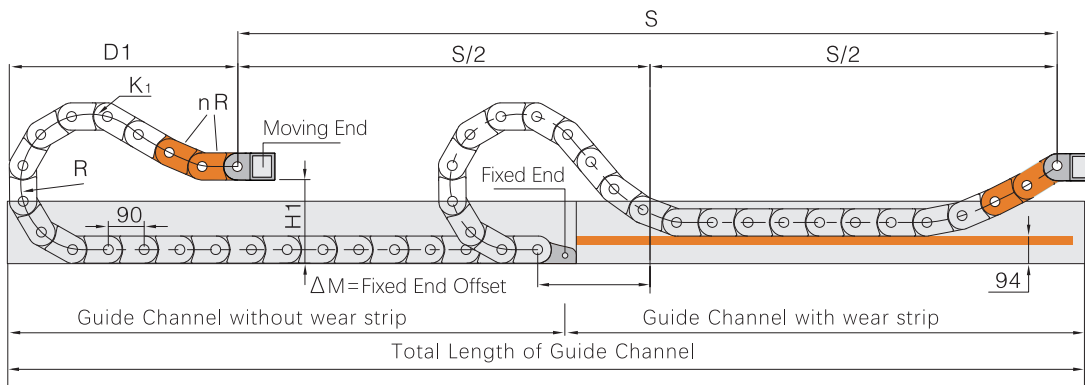

	125	150	200	250	300
R	125	150	200	250	300
H1	280	280	280	280	280
D1	310	500	710	980	1180
K1	580	820	1270	1640	2000
ΔC	--	210	359	510	710
nR	--	2	2	3	3

Yellow Buckle Heavy Duty | Z Series | Installation Dimensions

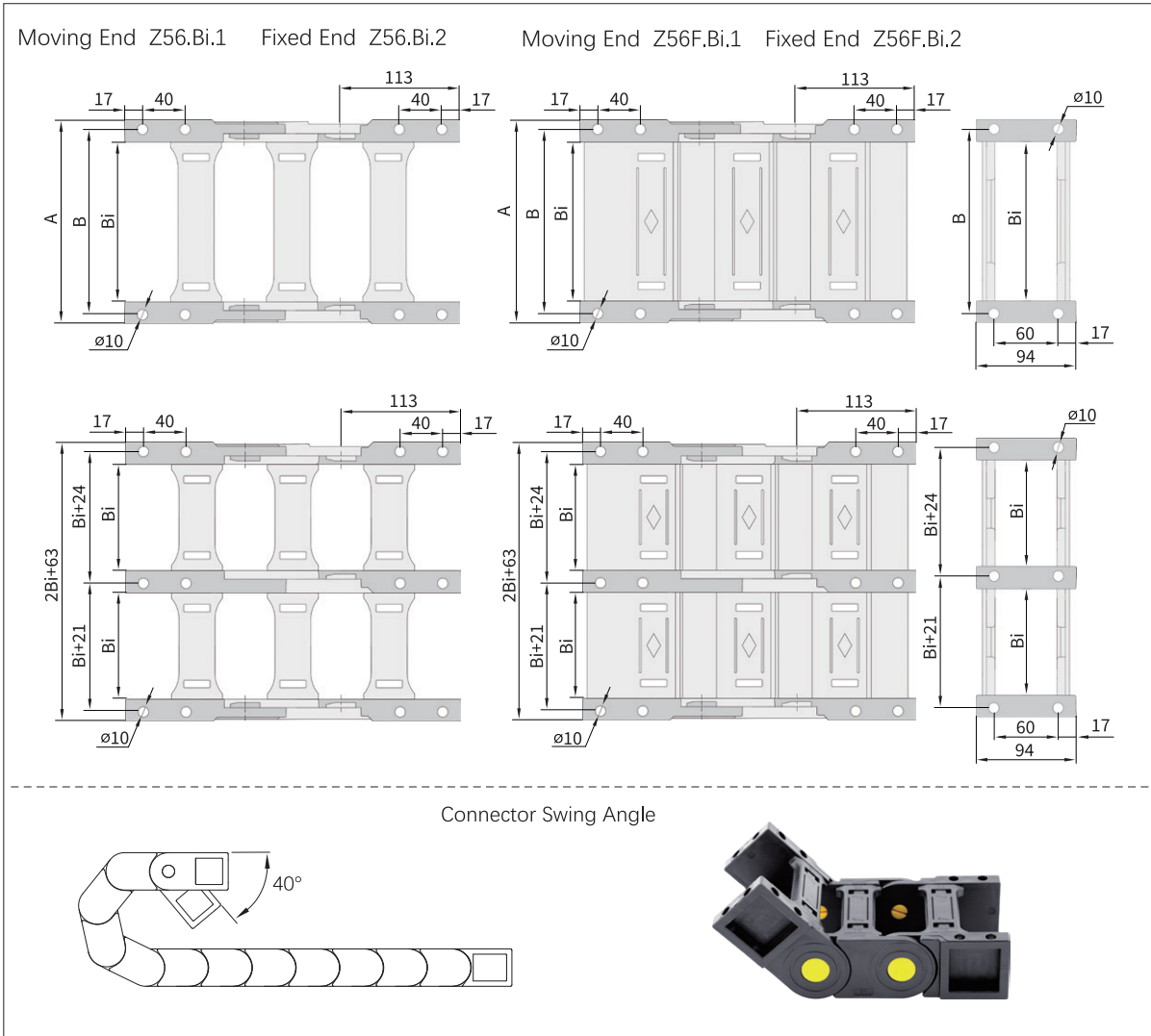

Product Code Complete Set	A [mm]	B [mm]	Bi [mm]
Z.056Q.060.12	102	84	60
Z.056Q.095.12	137	119	95
Z.056Q.125.12	167	149	125
Z.056Q.150.12	192	174	150
Z.056Q.175.12	217	199	175
Z.056Q.200.12	242	224	200
Z.056Q.225.12	267	249	225
Z.056Q.250.12	292	274	250
Z.056Q.300.12	342	324	300

Product Code Complete Set	A [mm]	B [mm]	Bi [mm]
Z.056F.100.12	142	124	100
Z.056F.150.12	192	174	150
Z.056F.200.12	242	224	200

Separation Principle | Vertical Divider Horizontal Divider

Note:

Minimum distance D_{min} between vertical divider and side plate inner wall = 36mm. Standard configuration: one set of dividers per two links.

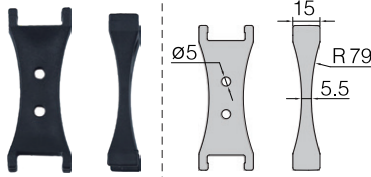
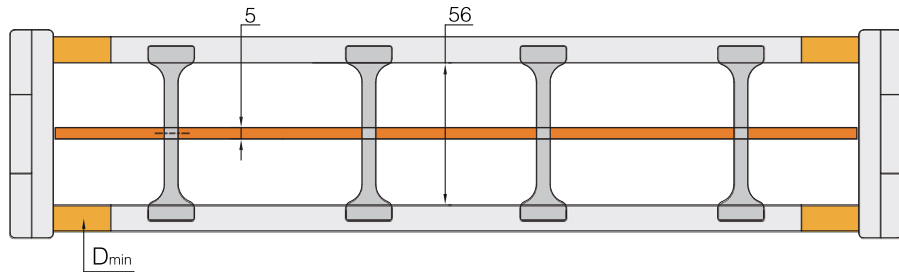

Vertical Divider / Standard Type / Suitable for most applications; wide base for stable installation inside drag chain.

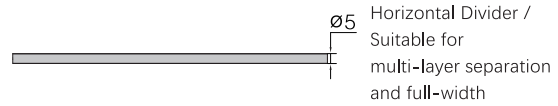

Horizontal Divider / Suitable for multi-layer separation and full-width



Ordering Example

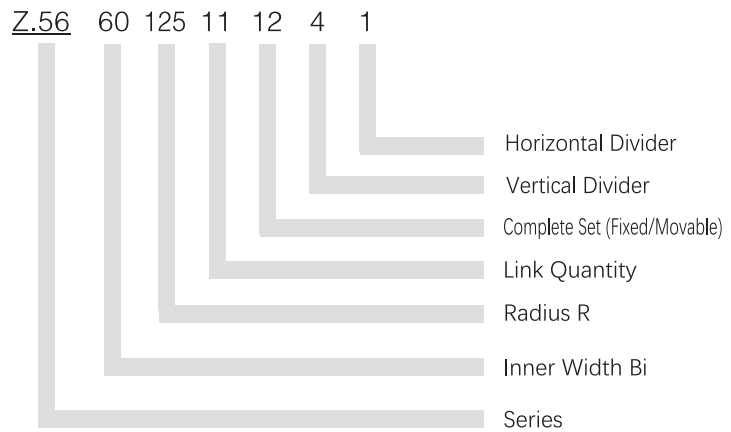
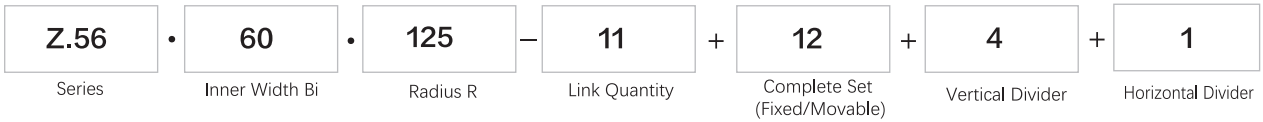

Yellow Buckle Heavy Duty 62 Series

Yellow Buckle Heavy Duty | Z Series | Product Range

Rigid structure Heavy load capacity



Drag Chain | Z Series | Bridge type, upper & lower cover openable

Product Code Drag Chain	Bi [mm]	Ba [mm]	R [mm]	Weight [kg/m]
Z.62Q.60.R	60	103	150 175 200 225 250 300 400 500	≈ 3.97
Z.62Q.95.R	95	138	150 175 200 225 250 300 400 500	≈ 4.25
Z.62Q.125.R	125	168	150 175 200 225 250 300 400 500	≈ 4.44
Z.62Q.150.R	150	193	150 175 200 225 250 300 400 500	≈ 4.59
Z.62Q.175.R	175	218	150 175 200 225 250 300 400 500	≈ 4.70
Z.62Q.200.R	200	243	150 175 200 225 250 300 400 500	≈ 4.82
Z.62Q.225.R	225	268	150 175 200 225 250 300 400 500	≈ 5.14
Z.62Q.250.R	250	293	150 175 200 225 250 300 400 500	≈ 5.42
Z.62Q.300.R	300	343	150 175 200 225 250 300 400 500	≈ 5.74

Complete the model number according to the required bending radius (R), Example: Z.62.60.R.150



Drag Chain | Z Series | Fully enclosed, upper & lower cover openable

Product Code Drag Chain	Bi [mm]	Ba [mm]	R [mm]	Weight [kg/m]
Z.62F.100.R	100	143	150 175 200 225 250 300 400 500	≈ 3.71
Z.62F.150.R	150	193	150 175 200 225 250 300 400 500	≈ 5.25
Z.62F.200.R	200	243	150 175 200 225 250 300 400 500	≈ 6.18

Complete the model number according to the required bending radius (R), Example: Z.62.100.R.150

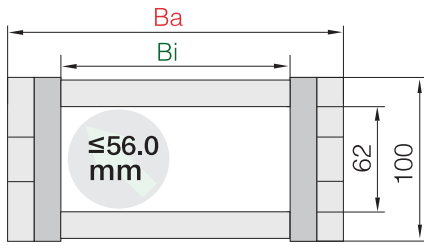

Inner [mm]	62
Height Pitch [mm/link]	100
Number /m	10
= [mm]	1000
Chain Length	$L_k = \frac{S}{2} + K$

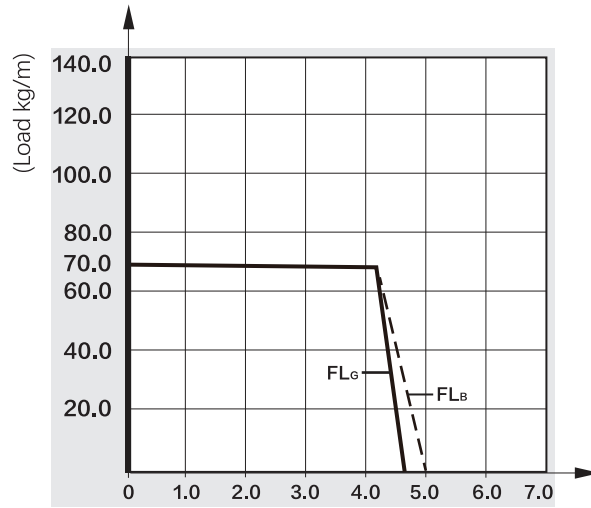

Overhead Operation FLG/FLB [m] Travel Distance S [m]

FLG= Straight Overhead FLB= Safe Sagging Overhead

Overhead Application | Short Travel

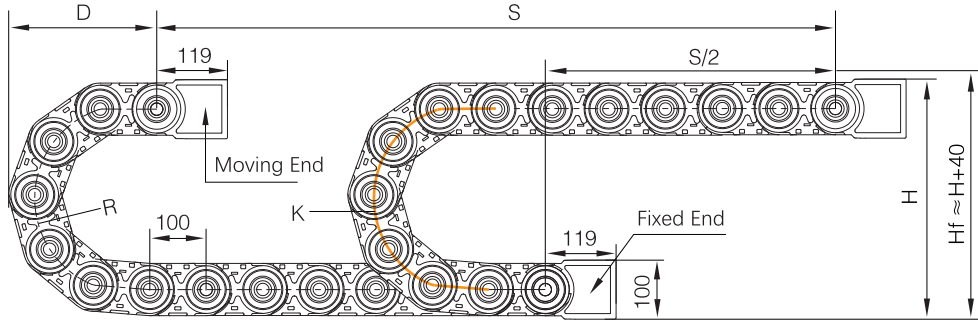

R	150	175	200	225	250	300	400	500
H	387	437	487	537	587	687	887	1087
D	350	375	400	425	450	500	600	700
K	670	750	830	910	985	1145	1455	1770

Actual Installation Height: $H_f \approx H + 40\text{mm}$

Sliding Application | Long Travels : $L_k = S/2 + K_1 + \Delta M$

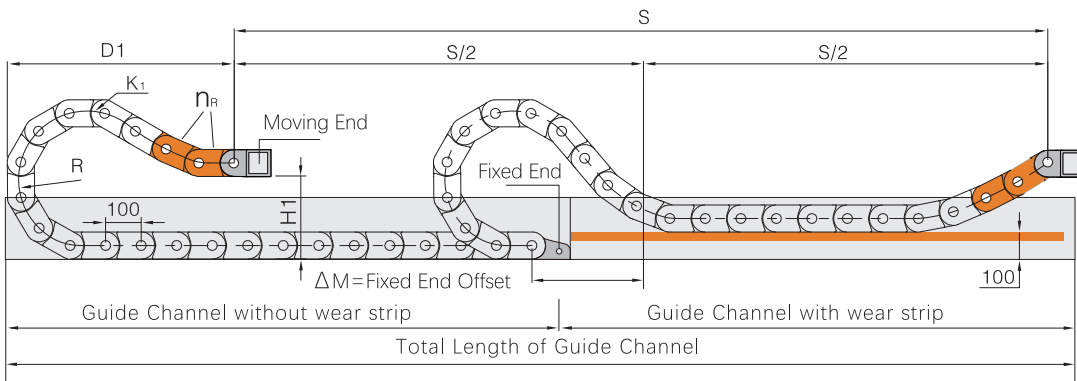

R	150	175	200	225	250	300	400	500
H1	300	310	310	310	310	310	310	310
D1	500	600	760	850	960	1160	1560	1960
K1	860	1060	1300	1460	1650	1950	2600	3320
ΔC	175	290	375	450	525	700	975	1280
nR	--	2	2	2	3	3	4	4

Yellow Buckle Heavy Duty | Z Series | Installation Dimensions

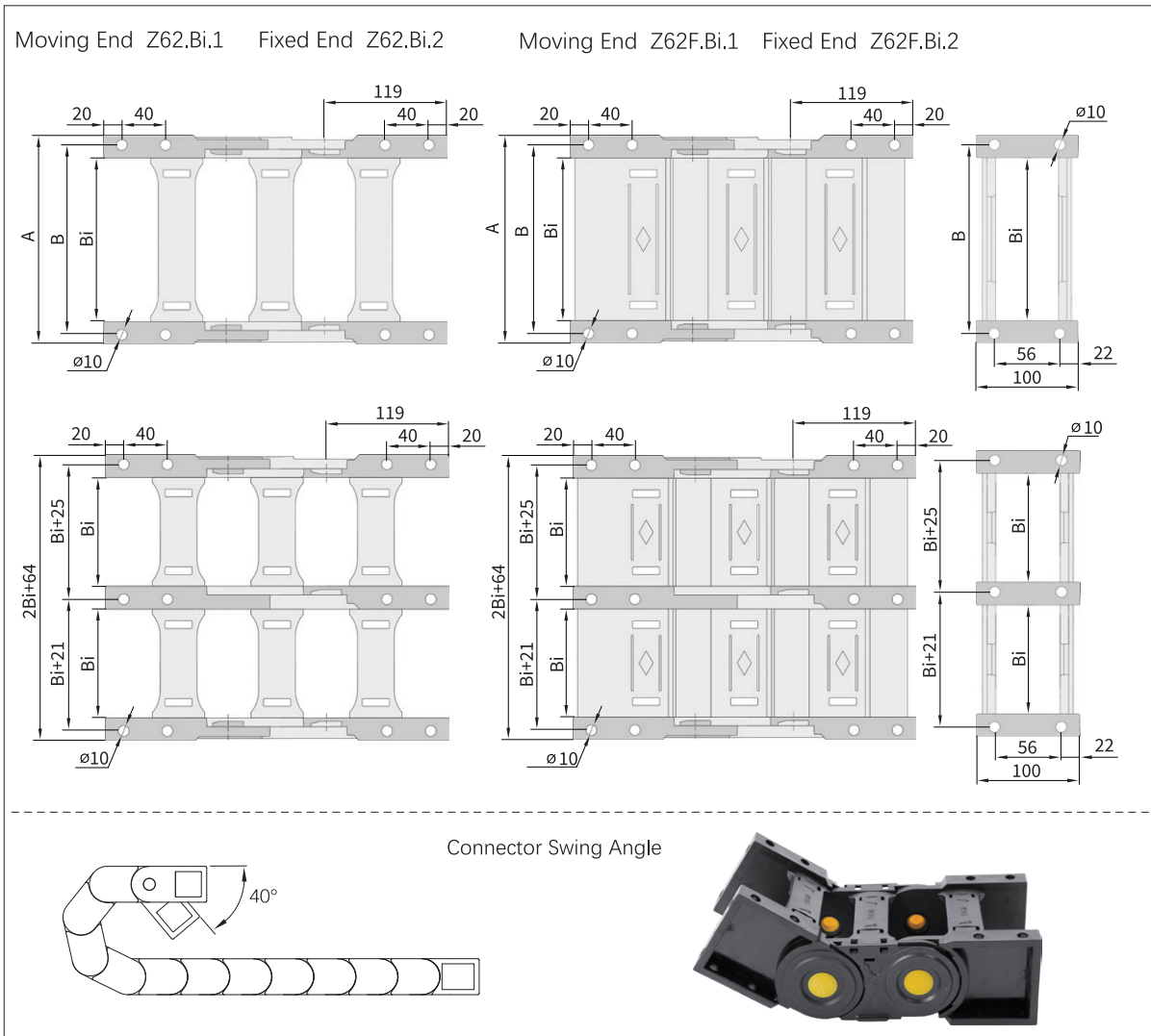

Product Code Complete Set	A [mm]	B [mm]	Bi [mm]
Z.062Q.060.12	103	85	60
Z.062Q.095.12	138	110	95
Z.062Q.125.12	168	140	125
Z.062Q.150.12	193	175	150
Z.062Q.175.12	218	190	175
Z.062Q.200.12	243	225	200
Z.062Q.225.12	268	240	225
Z.062Q.250.12	293	275	250
Z.062Q.300.12	343	325	300

Product Code Complete Set	A [mm]	B [mm]	Bi [mm]
Z.062F.100.12	143	125	100
Z.062F.150.12	193	175	150
Z.062F.200.12	243	225	200

Separation Principle | Vertical Divider Horizontal Divider

Note:

Minimum distance D_{min} between vertical divider and side plate inner wall = 36mm. Standard configuration: one set of dividers per two links.

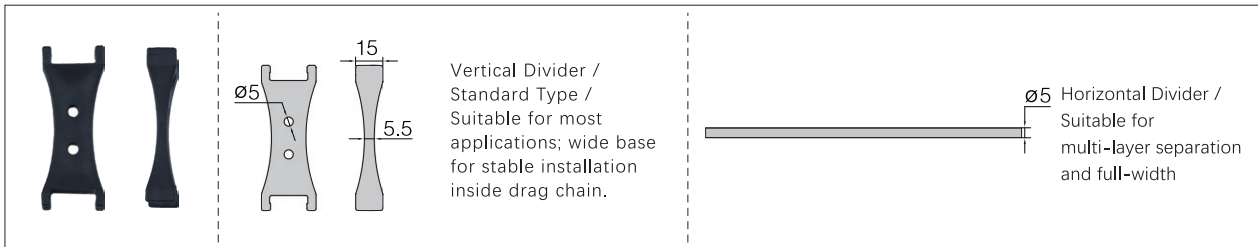
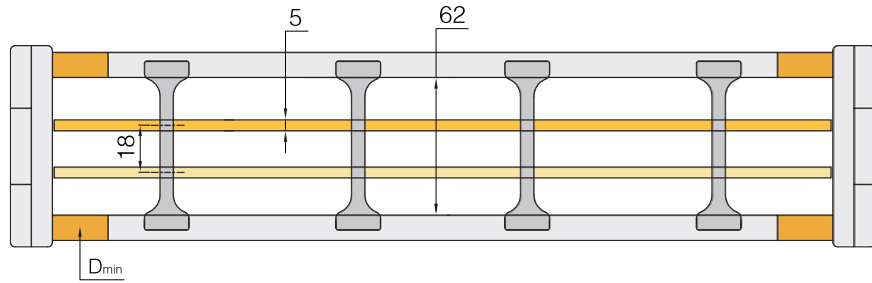

Ordering Example

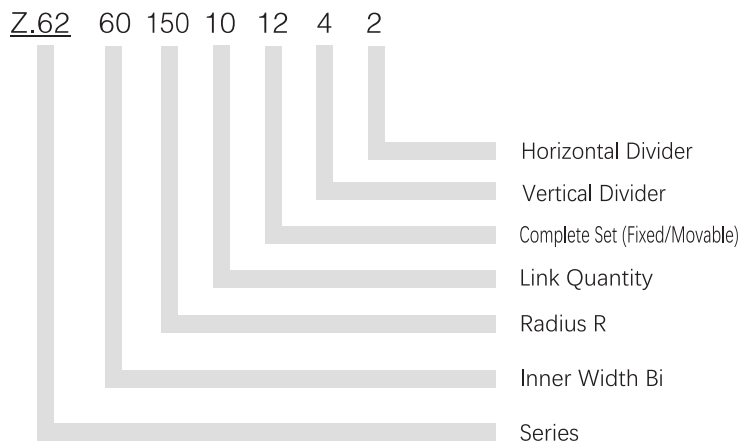
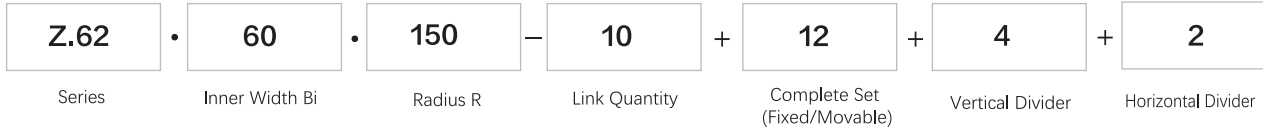

Yellow Buckle Heavy Duty 80 Series

Yellow Buckle Heavy Duty | Z Series | Product Range

Rigid structure Heavy load capacity



Drag Chain | Z Series | Bridge type, upper & lower cover openable

Product Code Drag Chain	Bi [mm]	Ba [mm]	R [mm]	Weight [kg/m]
Z.80Q.60.R	60	106	150 200 225 250 300 350 400 500 600	≈4.94
Z.80Q.95.R	95	141	150 200 225 250 300 350 400 500 600	≈5.19
Z.80Q.125.R	125	171	150 200 225 250 300 350 400 500 600	≈5.28
Z.80Q.150.R	150	196	150 200 225 250 300 350 400 500 600	≈5.41
Z.80Q.175.R	175	221	150 200 225 250 300 350 400 500 600	≈5.61
Z.80Q.200.R	200	246	150 200 225 250 300 350 400 500 600	≈5.71
Z.80Q.225.R	225	271	150 200 225 250 300 350 400 500 600	≈6.00
Z.80Q.250.R	250	296	150 200 225 250 300 350 400 500 600	≈6.26
Z.80Q.300.R	300	346	150 200 225 250 300 350 400 500 600	≈6.53

Complete the model number according to the required bending radius (R), Example: Z.80.60.R.150



Drag Chain | Z Series | Fully enclosed, upper & lower cover openable

Product Code Drag Chain	Bi [mm]	Ba [mm]	R [mm]	Weight [kg/m]
Z.80F.150.R	150	196	150 200 225 250 300 350 400 500 600	≈5.85
Z.80F.175.R	175	224	150 200 225 250 300 350 100 500 600	≈6.05
Z.80F.300.R	300	346	150 200 225 250 300 350 100 500 600	≈8.52

Complete the model number according to the required bending radius (R), Example: Z.80.150.R.150

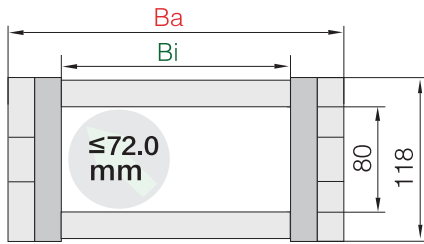

Inner [mm]	80
Height Pitch [mm/link]	118
Number /m	9
= [mm]	990
Chain Length	$L_k = \frac{S}{2} + K$

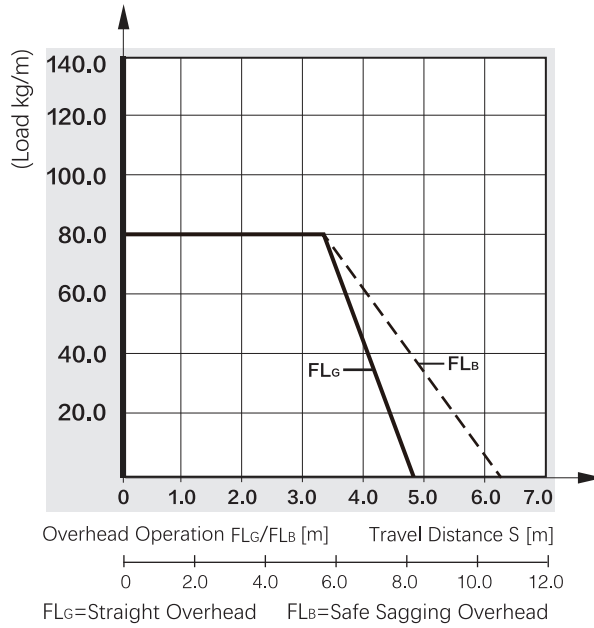

Overhead Application | Short Travel

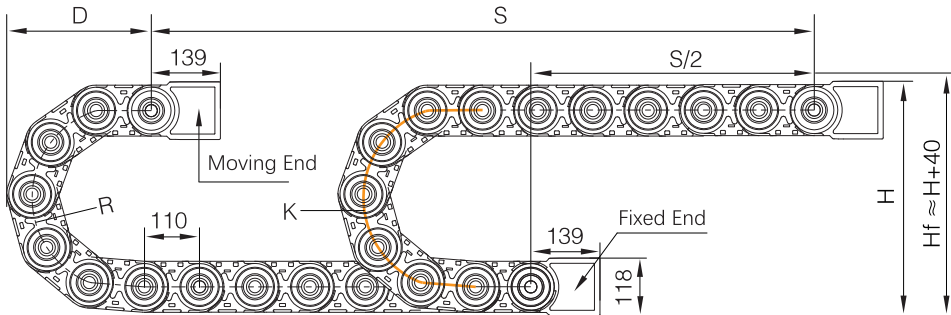

R	150	200	225	250	300	350	400	500	600
H	418	518	568	618	718	818	918	1118	1318
D	370	420	445	470	520	570	620	720	820
K	695	850	930	1105	1162	1320	1476	1790	2100

Actual Installation Height: $H_f \approx H + 40\text{mm}$

Sliding Application | Long Travels : $L_k = S/2 + K_1 + \Delta M$

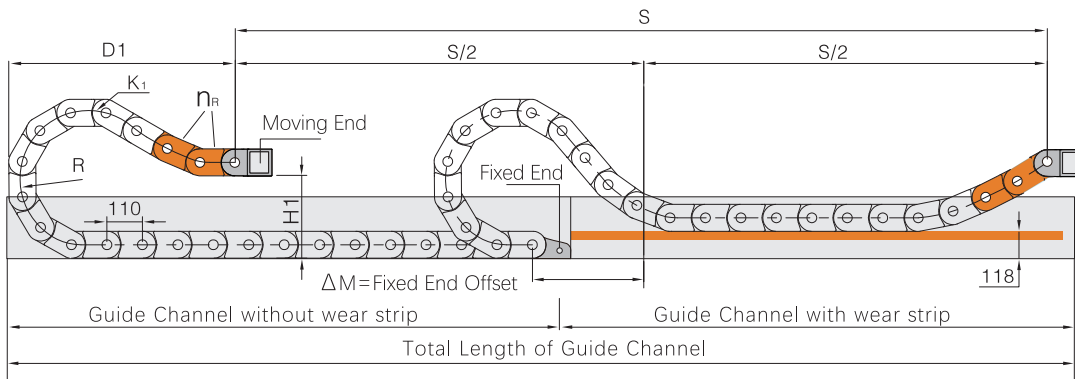

R	150	200	225	250	300	350	400	500	600
H _i	300	320	320	320	320	320	320	320	320
D ₁	555	805	900	1000	1200	1450	1600	2110	2500
K ₁	895	1335	1500	1670	2000	2330	2660	3450	4100
ΔC	190	390	465	540	690	890	990	1390	1690
n _R	--	2	2	2	3	3	4	4	4

Yellow Buckle Heavy Duty | Z Series | Installation Dimensions

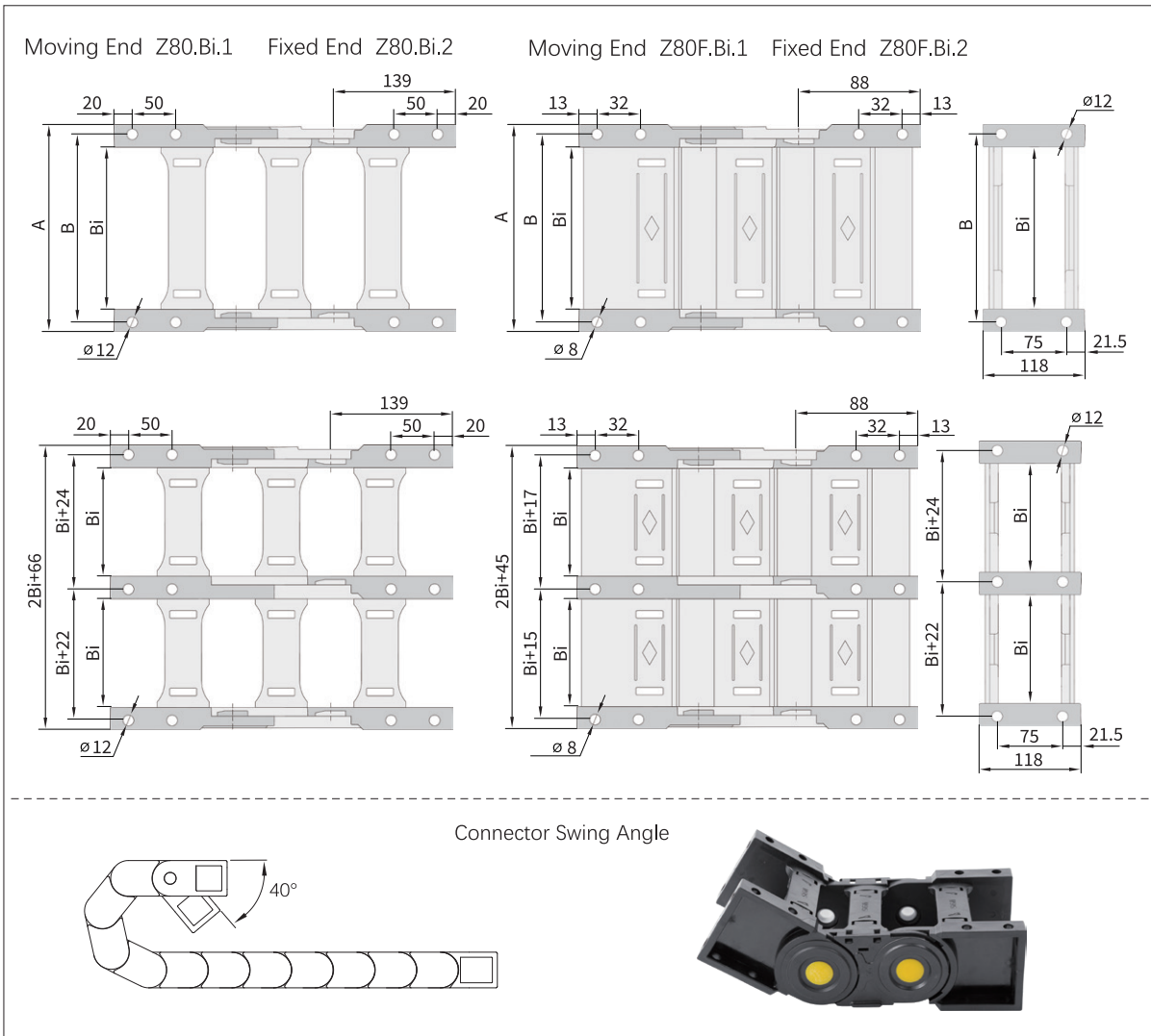

Product Code Complete Set	A [mm]	B [mm]	Bi [mm]
Z.080Q.060.12	106	84	60
Z.080Q.095.12	141	119	95
Z.080Q.125.12	171	149	125
Z.080Q.150.12	196	174	150
Z.080Q.175.12	221	199	175
Z.080Q.200.12	246	224	200
Z.080Q.225.12	271	249	225
Z.080Q.250.12	296	274	250
Z.080Q.300.12	346	324	300

Product Code Complete Set	A [mm]	B [mm]	Bi [mm]
Z.080F.150.12	196	174	150
Z.080F.175.12	221	199	175
Z.080F.300.12	346	324	300

Separation Principle | Vertical Divider Horizontal Divider

Note:

Minimum distance D_{min} between vertical divider and side plate inner wall = 36mm. Standard configuration: one set of dividers per two links.

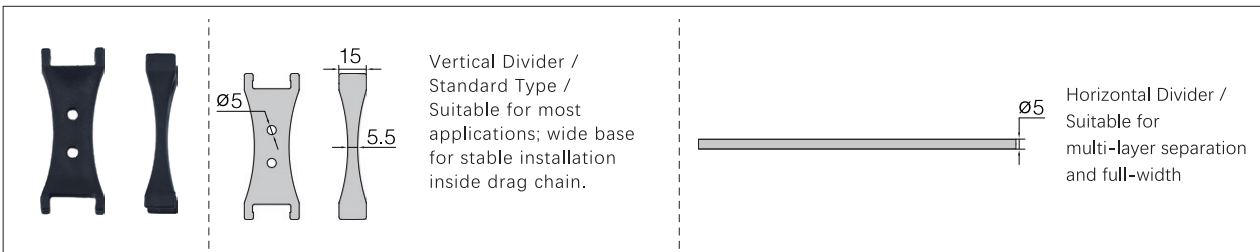
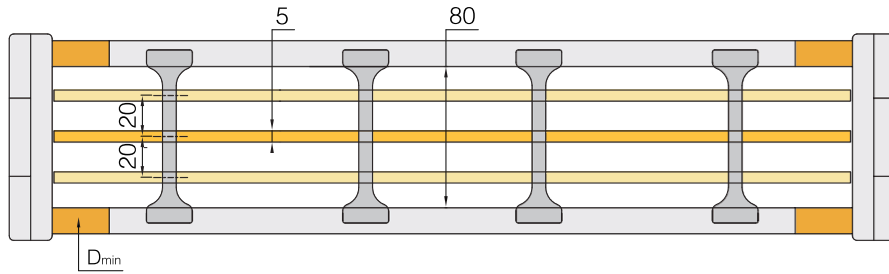

Ordering Example

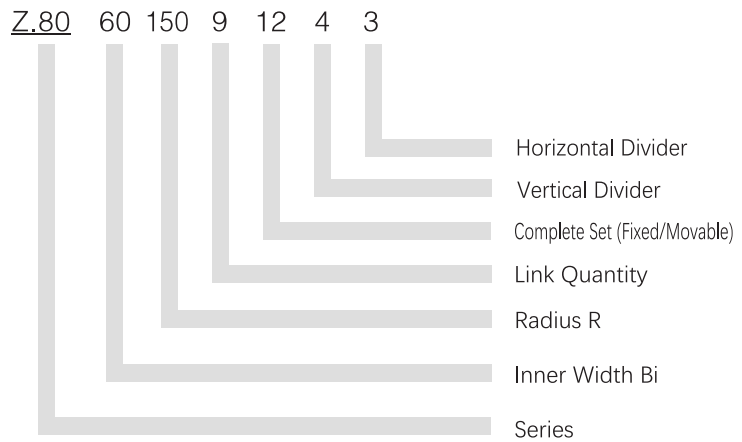
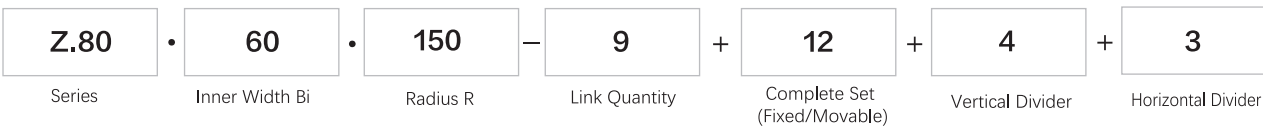



Low Noise 25 Series

Low Noise | JY Series | Product Range

Low noise Low vibration

Low Noise Series



Drag Chain | JY Series | Bridge type, upper & lower cover openable

Product Code Drag Chain	Bi [mm]	Ba [mm]	R [mm]	Weight [kg/m]
JY.25.38.R	38	59	055 075 100	≈1.23
JY.25.50.R	50	71	055 075 100	≈1.33
JY.25.57.R	57	78	055 075 100	≈1.38
JY.25.75.R	75	96	055 075 100	≈1.49
JY.25.100.R	100	121	055 075 100	≈1.61

Complete the model number according to the required bending radius (R), Example: JY.25.38.R.055

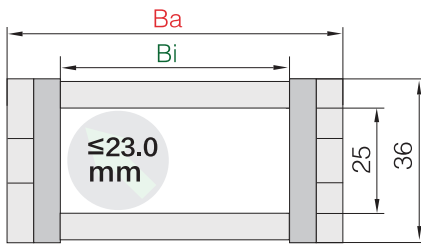

Inner [mm]	25
Height Pitch [mm/link]	22
Number /m	46
= [mm]	1012
Chain Length	$L_k = \frac{S}{2} + K$

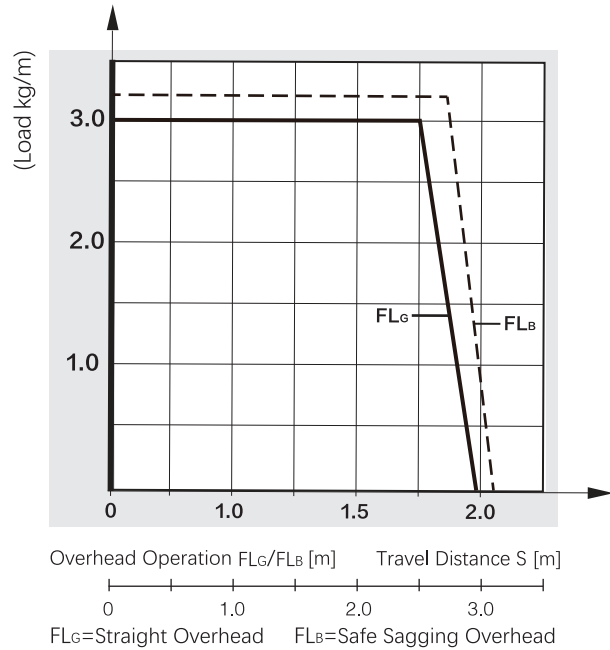

Overhead Application | Short Travel

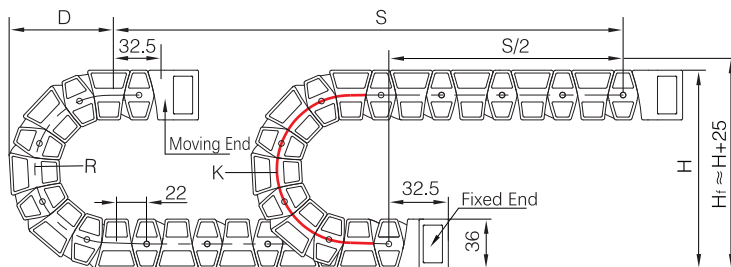

R	055	075	100
H	146	186	236
D	99	119	144
K	217	280	358

Actual Installation Height: HF ≈ H+25mm

Low Noise | JY Series | Installation Dimensions

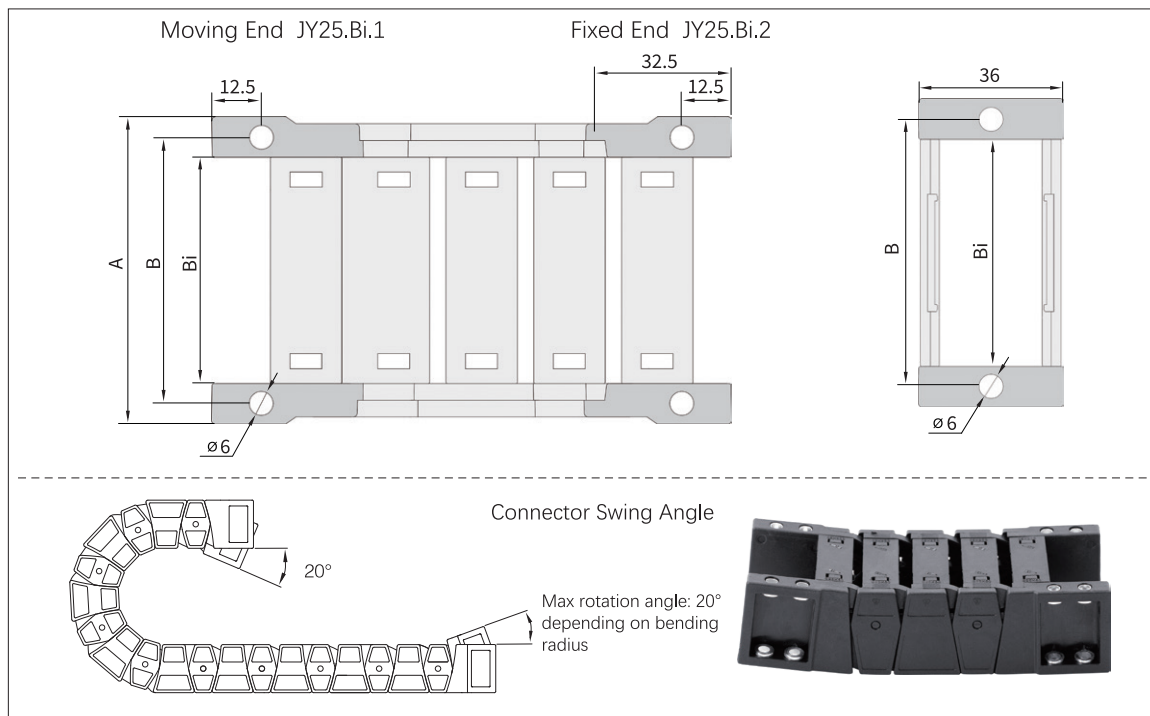

Product Code Complete Set	A [mm]	B [mm]	Bi [mm]
JY.025.038.12	59	48	38
JY.025.050.12	71	60	50
JY.025.057.12	78	67	57
JY.025.075.12	96	85	75
JY.025.100.12	121	110	100

Separation Principle | Vertical Divider Horizontal Divider

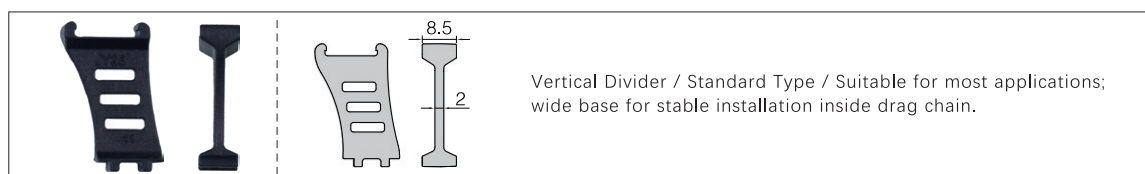
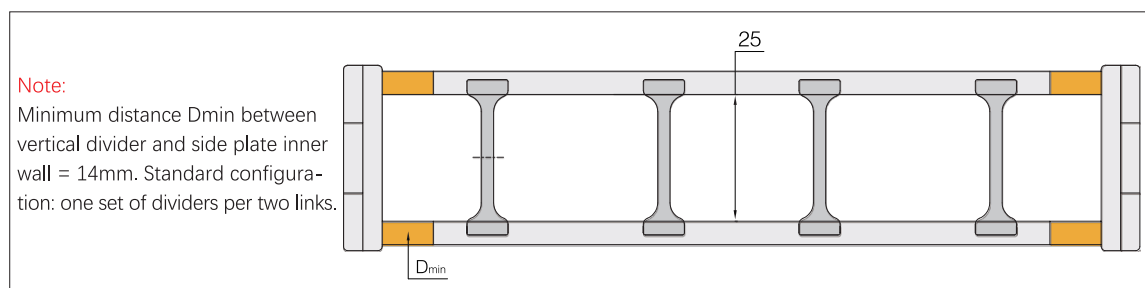

Ordering Example

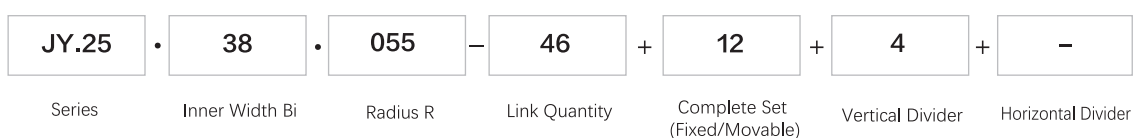

Low Noise | JY Series | Product Range

Low noise Low vibration



Drag Chain | JY Series | Bridge type, upper & lower cover openable

Product Code Drag Chain	Bi [mm]	Ba [mm]	R [mm]	Weight [kg/m]
JY.35.50.R	50	74	075 100 150	≈ 2.09
JY.35.75.R	75	99	075 100 150	≈ 2.25
JY.35.100.R	100	124	075 100 150	≈ 2.40

Complete the model number according to the required bending radius (R), Example: JY.35.50.R.075

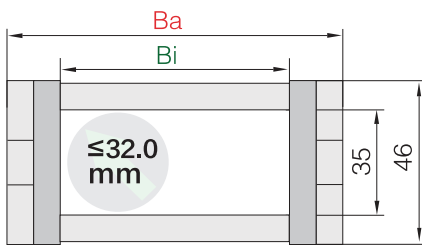

Inner [mm]	35
Height Pitch [mm/link]	25
Number /m	40
= [mm]	1000
Chain Length	$L_K = \frac{S}{2} + K$

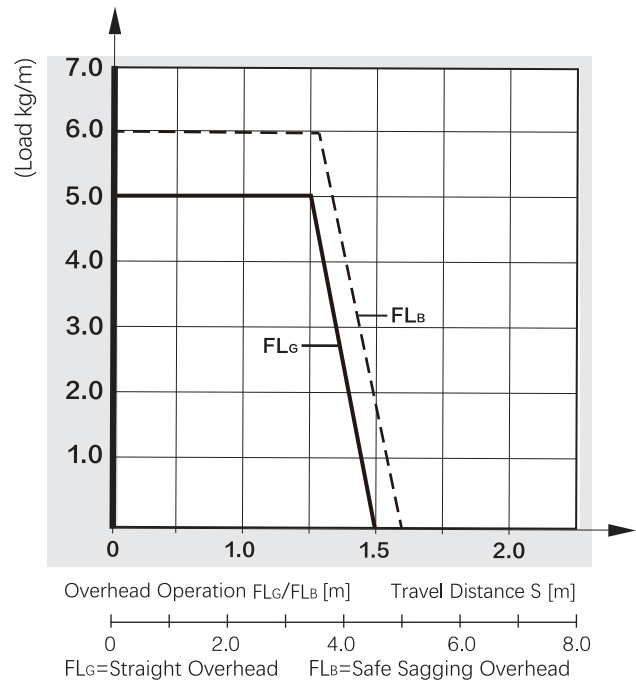

Overhead Application | Short Travel

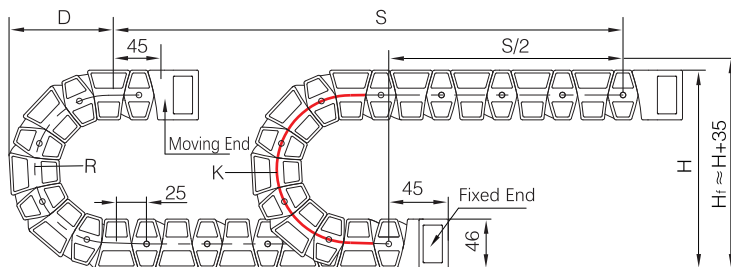

R	055	075	100
H	156	196	246
D	130	150	200
K	223	286	364

Actual Installation Height: $H_f \approx H + 35\text{mm}$

Low Noise | JY Series | Installation Dimensions

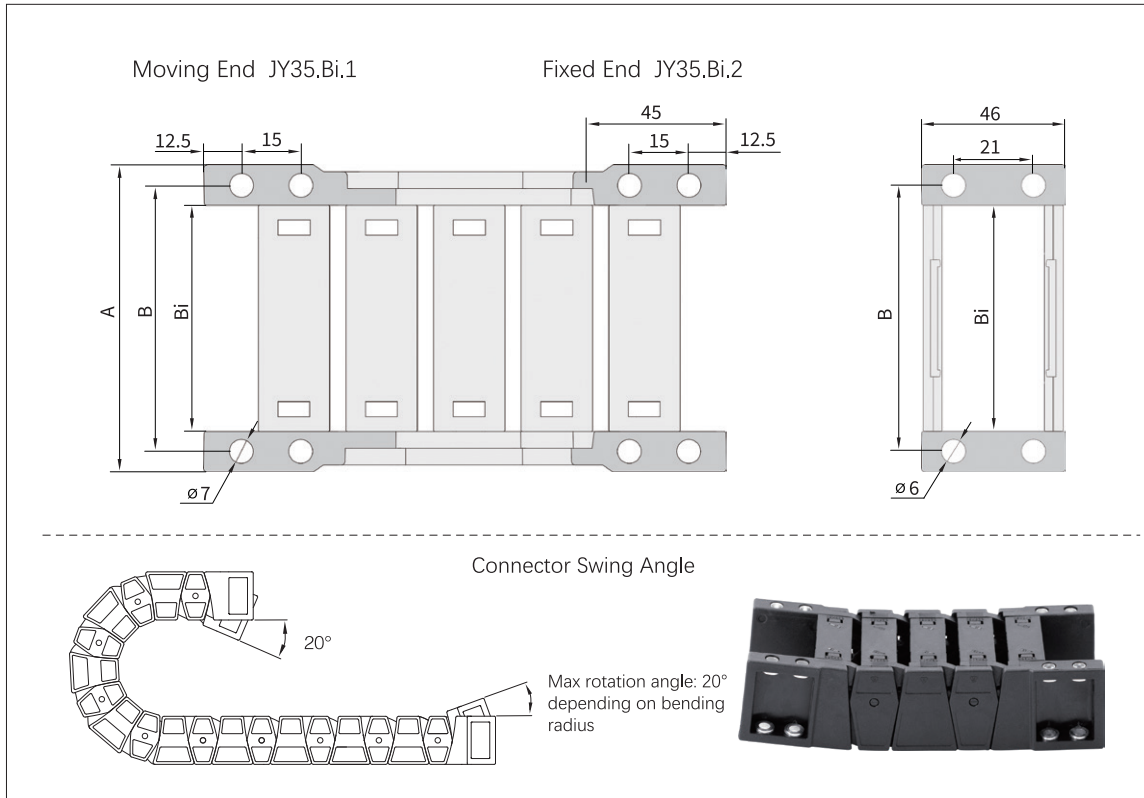

Product Code Complete Set	A [mm]	B [mm]	Bi [mm]
JY.035.050.12	74	62	50
JY.035.075.12	99	87	75
JY.035.100.12	124	112	100

Separation Principle | Vertical Divider Horizontal Divider

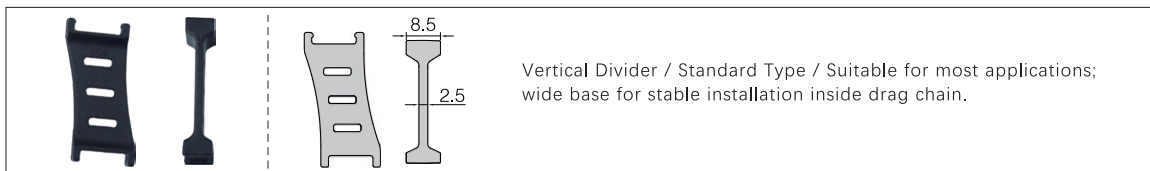
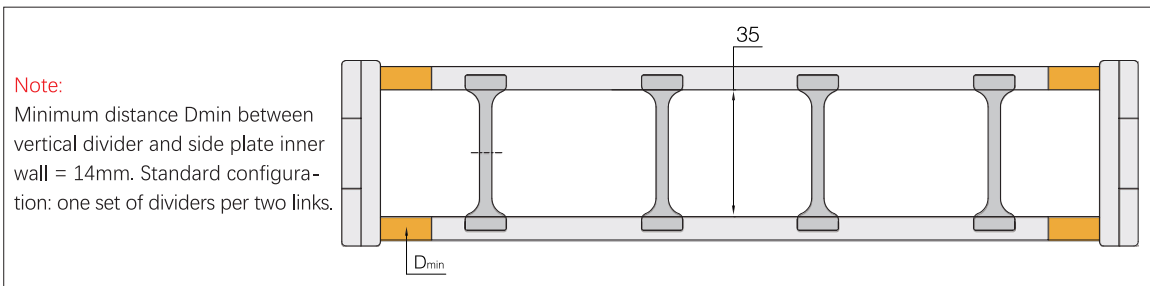

Ordering Example

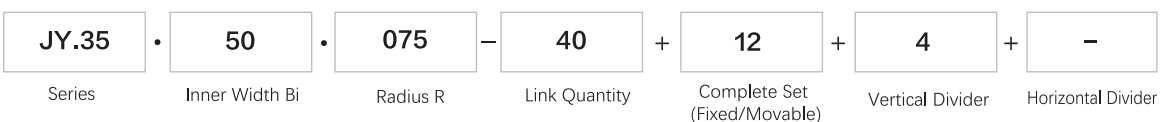



沧州盛昊

JIN'AO

TONEX[®]

Cangzhou Shenghao Machine Tool Accessories Co., Ltd.

Tel: +86 0317 2121965

E-mail: czshenghao@163.com

www.czshenghao.cn

Cangzhou Jin Ao Trading Co., Ltd

Tel: +86 0317 3069077

E-mail: admin@jin-ao.net

www.jinaobellowscover.com

Hebei Tonex Rubber And Plastic Co., Ltd.

Tel: +86 15530450768

E-mail: bill@tongflex.com

www.tonexdragchain.com